

# SMARTLIFT

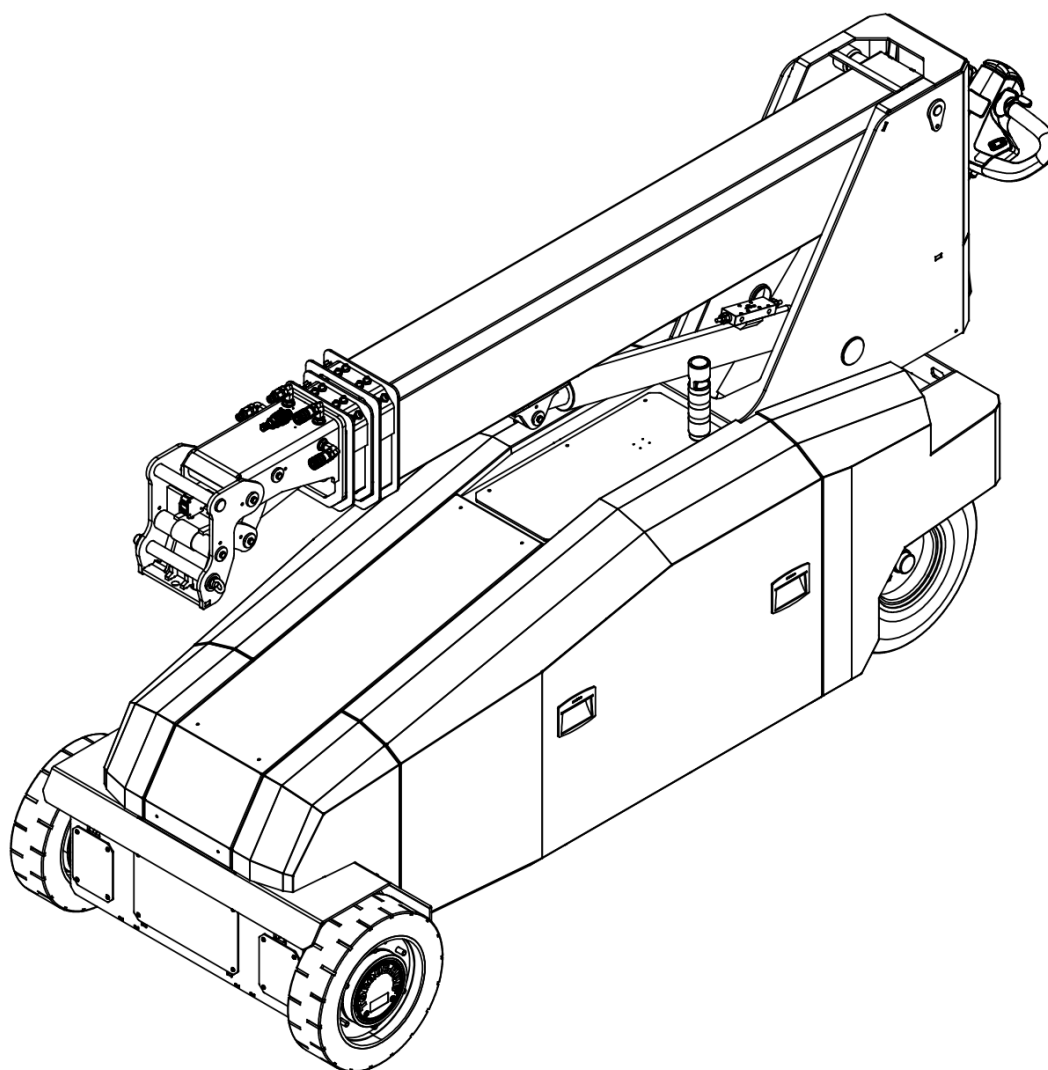

## SLX 2000 and attachments

# User Manual

## English

Issued by:	Date:	Approved by:	Document name.:
TST	24/03/2026	MR	USER MANUAL - SLX 2000 EN 01

## Table of contents

<b>1 Introduction .....</b>	<b>1</b>
1.1 Smartlift customer service .....	1
1.2 Reading guide.....	1
1.3 About the operating manual .....	2
1.4 Machine types covered .....	3
1.5 Nameplate .....	3
<b>2 Safety and residual risks .....</b>	<b>4</b>
2.1 Safety instructions.....	4
2.2 Emergencies.....	5
2.3 Personal protection equipment.....	6
2.4 Safety switch – Belly button .....	7
<b>3 Overview and use .....</b>	<b>8</b>
3.1 Machine overview .....	8
3.2 Attachment overview.....	11
3.3 Label overview.....	14
3.4 Technical Specifications – Machine .....	15
3.5 Technical Specifications – Attachments .....	16
3.6 Operating limits.....	19
3.7 Operating limits – Attachments .....	21
<b>4 Operating .....</b>	<b>23</b>
4.1 Before operating .....	23
4.2 Operating in general .....	23
4.3 Driving the machine with the control handle: .....	23
4.4 Driving the machine with the remote control (Option): .....	24
4.5 Signals.....	25
4.6 After operating .....	26
4.7 Functional overview .....	29
4.8 Attachment mounting instruction .....	36
<b>5 Storage and transport .....</b>	<b>37</b>
5.1 Storage .....	37
5.2 Transport .....	37
<b>6 Maintenance and troubleshooting.....</b>	<b>38</b>
6.1 Overview of service, maintenance and lubrication intervals .....	38
6.2 Functional inspection .....	40
6.3 Cleaning the machine and attachments .....	41
6.4 Troubleshooting .....	42
6.5 Fuses.....	43
6.6 Spare parts .....	44
<b>7 Scrapping and disposal .....</b>	<b>44</b>

Issued by:	Date:	Approved by:	Document name.:
TST	24/03/2026	MR	USER MANUAL - SLX 2000 EN 01



**8 Annexes .....44**

8.1 Terms and abbreviations.....44

8.2 Declaration of conformity – Machine .....45

8.3 Declaration of conformity – Attachments .....46

8.4 Load charts .....47

Issued by:	Date:	Approved by:	Document name.:
TST	24/03/2026	MR	USER MANUAL - SLX 2000 EN 01

# 1 Introduction

Smartlift A/S is an innovative company which develops and manufactures smart lifts, which are marketed worldwide. A Smartlift is characterized by the highest levels of precision, reliability and quality.

The **SLX machines** are designed as a multi-purpose lifting machine for construction sites and in industry. The machines have been developed with a focus on user-friendliness and flexibility and can thereby solve most tasks with the right attachment.

## 1.1 Smartlift customer service

Smartlift customer service

tel. +45 97 72 29 11

email: [Customerservice@smartlift.com](mailto:Customerservice@smartlift.com)

## 1.2 Reading guide

These instructions have been prepared in accordance with DS/EN ISO 20607:2019 Safety of machinery – Operating instructions – General principles for design, and they are the manufacturer's original operating instructions for the machines.

The operating manual provides the user with the information necessary to operate the machine effectively and safely throughout the machine's service life. General safety instructions and conditions are described in a separate section, after which the machine and its intended use are described.

The operating manual is aimed at all users of the machine and is structured according to the user's functions and interactions with the machine. Security-related information and instructions appear either as sections or as general information for all users.

When reviewing the operating manual, the following approach is recommended:



- Identify yourself as belonging to one or more user groups before using the machine.
- Read and understand the contents of the operating manual, including information and instructions. If applicable, you only need to read those which are aimed at your particular user type.

In case of uncertainty regarding the above, contact your immediate supervisor.

Issued by:	Date:	Approved by:	Document name.:	Page
TST	24/03/2026	MR	USER MANUAL - SLX 2000 EN 01	1 of 51

## 1.3 About the operating manual

The operating manual has been divided into a user manual and a service manual.

 <b>User manual Includes:</b>	 <b>Service manual Includes:</b>
Machine overview	Parts lists
Safety instructions	Advanced troubleshooting
Operation of the machine	
Service forms	

The user manual must be stored in a place which is known and accessible to the user and to maintenance personnel.

The service manual must be stored in a place which is known and easily accessible to maintenance personnel.

It is the obligation of the employer (machine owner) to ensure that everyone who services, cleans, operates, maintains or repairs the machine has read the user manual and service manual, or at least the parts of them which are relevant to their work.

Additionally, anyone who operates, services, maintains or repairs the machine is under an obligation to seek information in both the user manual and service manual.

### 1.3.1 The user

"User" refers to an everyday user who is not a skilled worker in the particular field. The user is assumed to have been instructed in the safety and operation of the machine, and to be able to perform tasks within its field of work. For example, for operation, it is expected that the person is able to start and stop, check the proper centering of the vacuum yoke and remove items during normal operation.

It must be ensured that the person in question has been adequately instructed about the operating instructions and trained so that the work can be performed safely.

### 1.3.2 Maintenance personnel

Maintenance personnel must be qualified, either through having trained as e.g. blacksmiths, electricians or mechanics, or by being trained in a way that makes them equal to these professional groups. In addition, they must be familiar with the machine's operation and safety and know the location of the emergency stop.

Maintenance personnel must have read and understood the user manual, service manual, instructions, workplace instructions, etc.

Before commencing work, repairmen and maintenance personnel must be instructed about the machine's safety situation.



New maintenance personnel must be trained by an experienced colleague.

## 1.4 Machine types covered

The user manual covers the SLX 2000 machine which is part of the new Smartlift SLX series. These machines are equipped with a quick-change system that allows the use of a wide range of attachments such as vacuum yoke, hydraulic winch, fly-jib, pallet fork, and lifting hook. This makes them a highly versatile solution for handling a variety of lifting tasks on construction sites and in industrial environments.

## 1.5 Nameplate

The machine nameplate is placed inside the rear storage compartment.

 <b>SMARTLIFT</b>			
Smartlift A/S N.A. Christensensvej 39, DK-7900 Nykøbing Mors Tel.: +45 97 72 29 11, www.smartlift.dk			
Model:	<input type="text"/>		
Serial no.:	<input type="text"/>	Type:	<input type="text"/>
WLL:	<input type="text"/>	Year:	<input type="text"/>
Self-weight:	<input type="text"/>	Battery:	<input type="text"/>
Power:	<input type="text"/>		

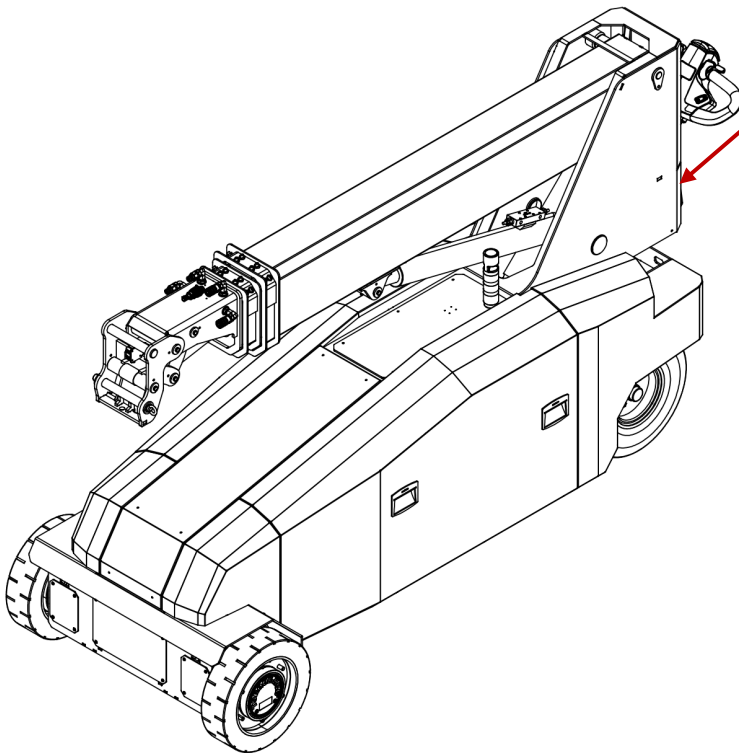

## 2 Safety and residual risks

### 2.1 Safety instructions

The machine and any associated attachments must only be operated by individuals who have received competent training in the functions and safe use of both the machine and its attachments. The users must fully understand the risks involved in operating the equipment. Before use, the user is required to have read and understood this user manual in its entirety. The user is solely responsible for ensuring that the machine and its attachments are always used correctly and safely. Additionally, the user must possess all legal required certifications and qualifications relevant to operation of this equipment.



#### It is forbidden to

- modifying the machine or any of its attachments.
- lifting or transport people using the machine or any of its attachments.
- being under or in front of the machine or any of its attachments when it is loaded.
- being under the machine if it is hoisted.
- exceeding the WLL of the machine or any of its attachments.
- exceeding the load chart of the machine or any of its attachments.
- operating and charge the machine simultaneously.
- lifting underneath the machine using a forklift or the like.
- operating the machine without wearing safety footwear.
- driving at high speed when going downhill.
- handling loads on slopes steeper than 2°.
- use the vacuum yoke attachment with fewer than 4 suction cups.
- use the vacuum yoke attachment to lift dirty, dusty, wet or grease items.
- use the vacuum yoke attachment to lift items that are not airtight.
- use the vacuum yoke without sufficient vacuum: Wait and verify that sufficient vacuum has been built up and that the vacuum pumps have stopped before performing any lifting!
- use the hydraulic winch attachment with fewer than 4 wraps of wire rope on the drum.
- use the pallet fork attachment without evenly distributing the load.
- use the pallet fork attachment without keeping the lifted items in horizontal position.



#### WARNING! Risk of danger!

- Never operate the machine or any attachments without having read this manual thoroughly.
- Never operate the machine or any attachments without having read and understood all safety labels and warnings on the machine and attachments.
- Never operate the machine or attachments if there are any visible damage or defects.
- Never operate the equipment without first assessing the surroundings, ground conditions, and weather.
- Always exercise extreme caution when operating the machine or any attachments.
- Operating the machine and attachments involves a risk of overturning.
- Always drive slowly and carefully when going down slopes.
- Always keep the load close to the ground while driving
- Never leave the machine loaded or on a slope.
- Always maintain a safe distance from the machine, its attachments and load during operation.



#### WARNING! Risk of explosion!

It is strictly forbidden to operate the machine or any attachments in environments with a risk of explosion, including ATEX-classified zones.

Issued by:	Date:	Approved by:	Document name.:	Page
TST	24/03/2026	MR	USER MANUAL - SLX 2000 EN 01	4 of 51

## 2.2 Emergencies

### 2.2.1 The machine catches fire

In the event of a fire in the machine, use a CO2 extinguisher.

### 2.2.2 Manual hydraulic pump

#### **WARNING!**

- Use of the manual hydraulic pump is associated with great danger and must only be used in case of an emergency or break down!
- The manual hydraulic pump bypasses all safety systems which may result in machine instability or tipping over!
- The following procedure must be conducted in the specified order to minimize the risk of instability or tipping over!

#### **ATTENTION! Procedure for safe retraction and lowering of boom!**

- A. Remove side cover.
- B. Loosen the small screw in the side of the disk (2) on the 3. valve from the left (5).
- C. Place the handle (3) on the manual hydraulic pump (4).
- D. Push down on the top of the 3. valve (5) while pumping the manual hydraulic pump (4).
  - a. Now the boom should start retracting slowly.
- E. When the boom is completely retracted stop pumping.
- F. Pull up the top of the 3. valve (5) and tighten the small screw in the side of the disk (2).
  - a. After tightening the screw, the disk (2) must still have vertical play.
- G. Pull up the top of the 2. valve (6) while pumping the manual hydraulic pump (4).
  - a. Now the boom should start lowering slowly.
- H. When the boom is lowered enough unload the machine slowly.

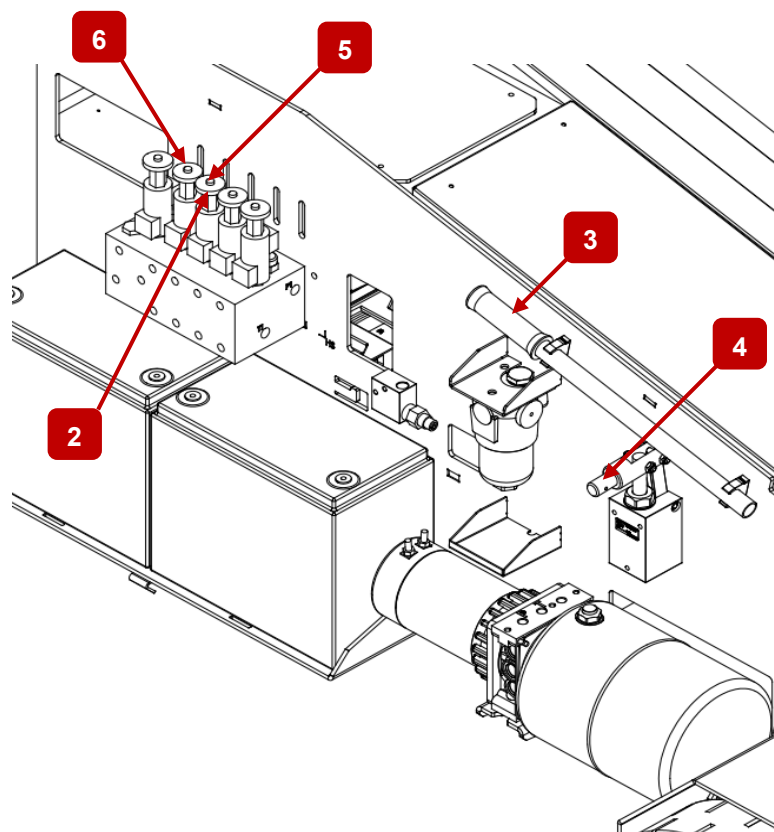

### 2.2.3 Towing the machine

**! ATTENTION!** Before towing the machine parking brakes on both drive motors must be released!

- Remove the center cover (1) on the motor consol.
- Pull both parking brake release mechanisms (2) and hold while the machine is towed.

**! ATTENTION!** Make sure that the parking brake is engaged after towing!

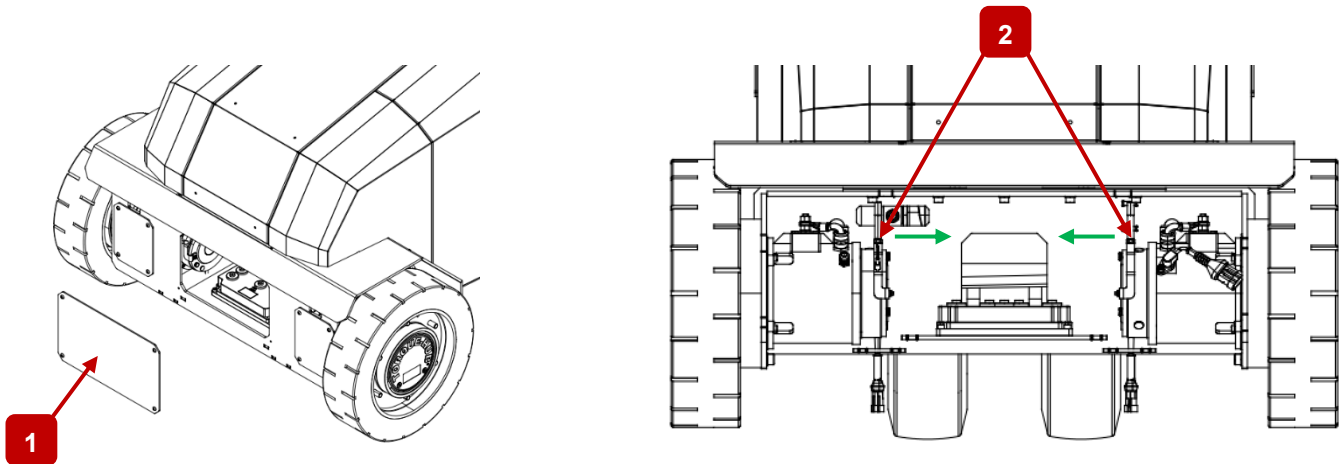

**! WARNING!**

- The machine's batteries contain acid!
- If the machine tips over, there is a risk that battery acid will leak out!
- If skin or eyes come into contact with battery acid, rinse them with plenty of clean water and consult a doctor!
- As the machine contains hydraulic oil, this must be collected in the event of spillage.

**! WARNING!** In case of a crash, the machine must undergo complete servicing!

## 2.3 Personal protection equipment

This section describes what personal protective equipment may be required when using the machine.

**! WARNING!** It is forbidden to use the machine without wearing safety footwear!



In addition, the following protective equipment is recommended: Safety helmet.



Issued by:	Date:	Approved by:	Document name.:	Page
TST	24/03/2026	MR	USER MANUAL - SLX 2000 EN 01	6 of 51

## 2.4 Safety switch – Belly button

If the machine is driven backwards and the belly button switch is triggered, the machine will automatically change the direction of travel for a short while. This reduces the risk of getting caught between objects and the machine.

### ! ATTENTION!

- The safety switch is only active when the foldable handlebar is down. If the handlebar is lifted the machine will stop!
- The safety switch is not active if the machine is driven with the remote control!

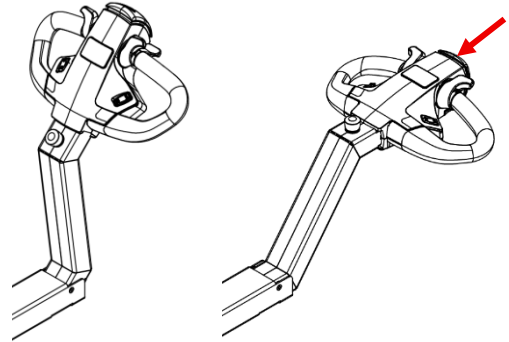

## 3 Overview and use

### 3.1 Machine overview

Here is an overview of the components that are mentioned in several places in this manual, and which are often referred to in everyday situations.

#### 3.1.1 Boom

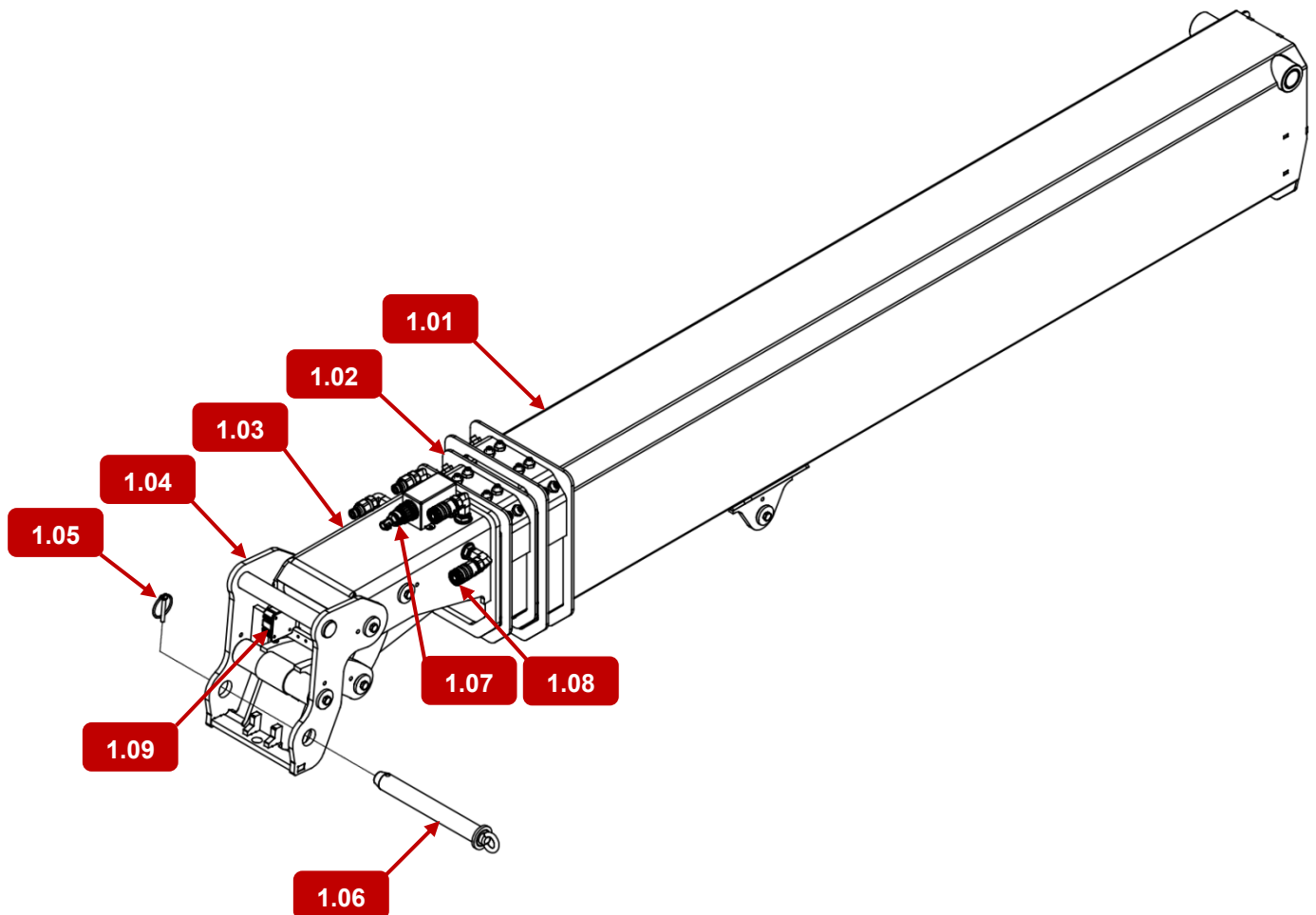

No.	Description	No.	Description	No.	Description
1.01	Main boom	1.04	Quick shift system	1.07	Wire connector
1.02	1. Extension boom	1.05	Linchpin	1.08	Hydraulic quick coupling
1.03	2. Extension boom	1.06	Locking shaft	1.09	Inclinometer

### 3.1.2 Base machine – Left side

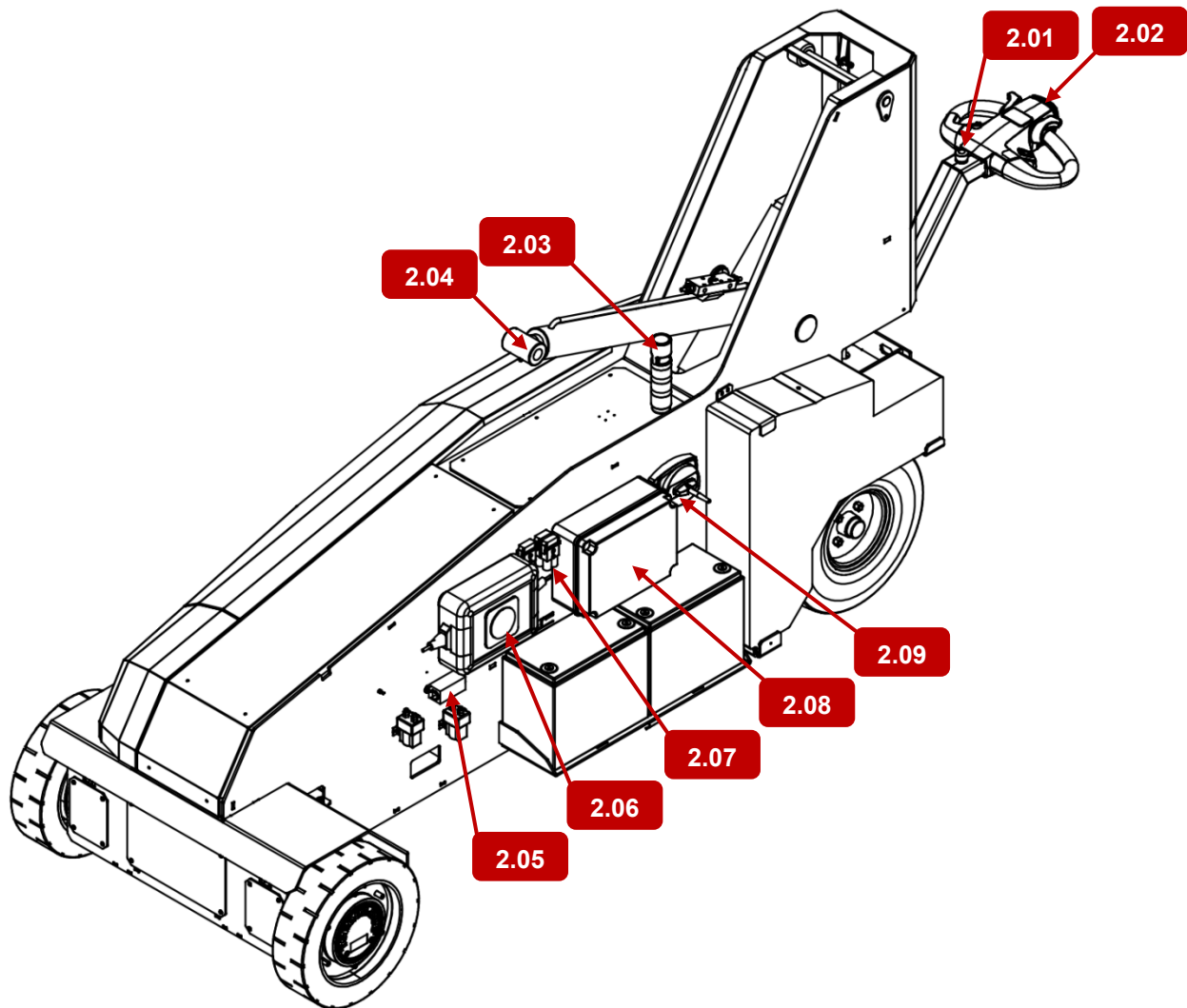

No.	Description	No.	Description	No.	Description
2.01	Emergency stop	2.04	Lift cylinder	2.07	Fuse holders (3 pcs.)
2.02	Control handle	2.05	Fuse holder	2.08	Control box
2.03	Tower light	2.06	Charger	2.09	Remote control receiver

### 3.1.3 Base machine – Right side

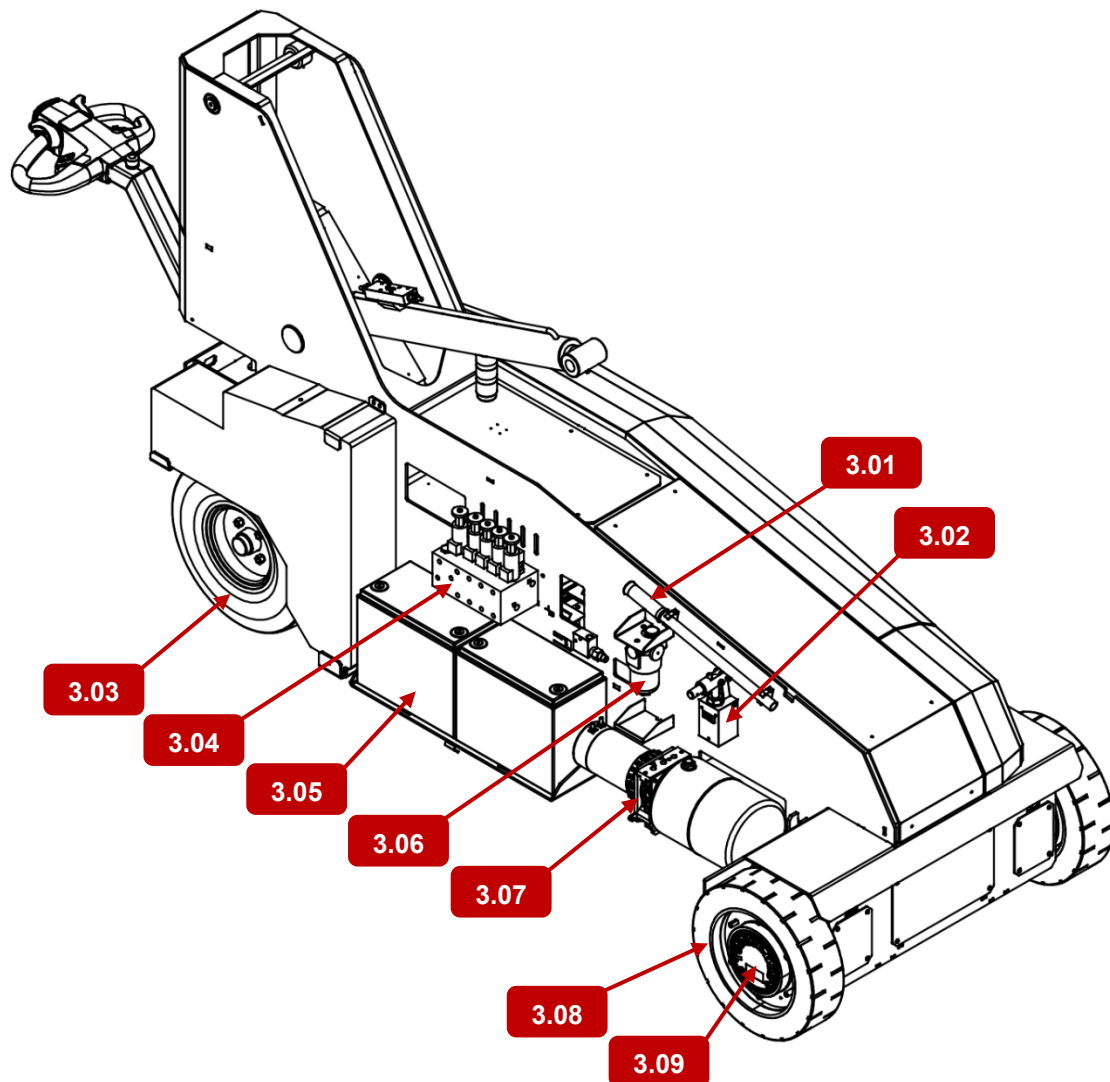

No.	Description	No.	Description	No.	Description
3.01	Handle for manual pump	3.04	Hydraulic manifold	3.07	Hydraulic pump
3.02	Manual hydraulic pump	3.05	Batteries	3.08	Drive motor
3.03	Rear wheel	3.06	Hydraulic filter	3.09	Front wheel

## 3.2 Attachment overview

Here is an overview of the components that are mentioned in several places in this manual, and which are often referred to in everyday situations.

### 3.2.1 Attachment overview – Vacuum yoke

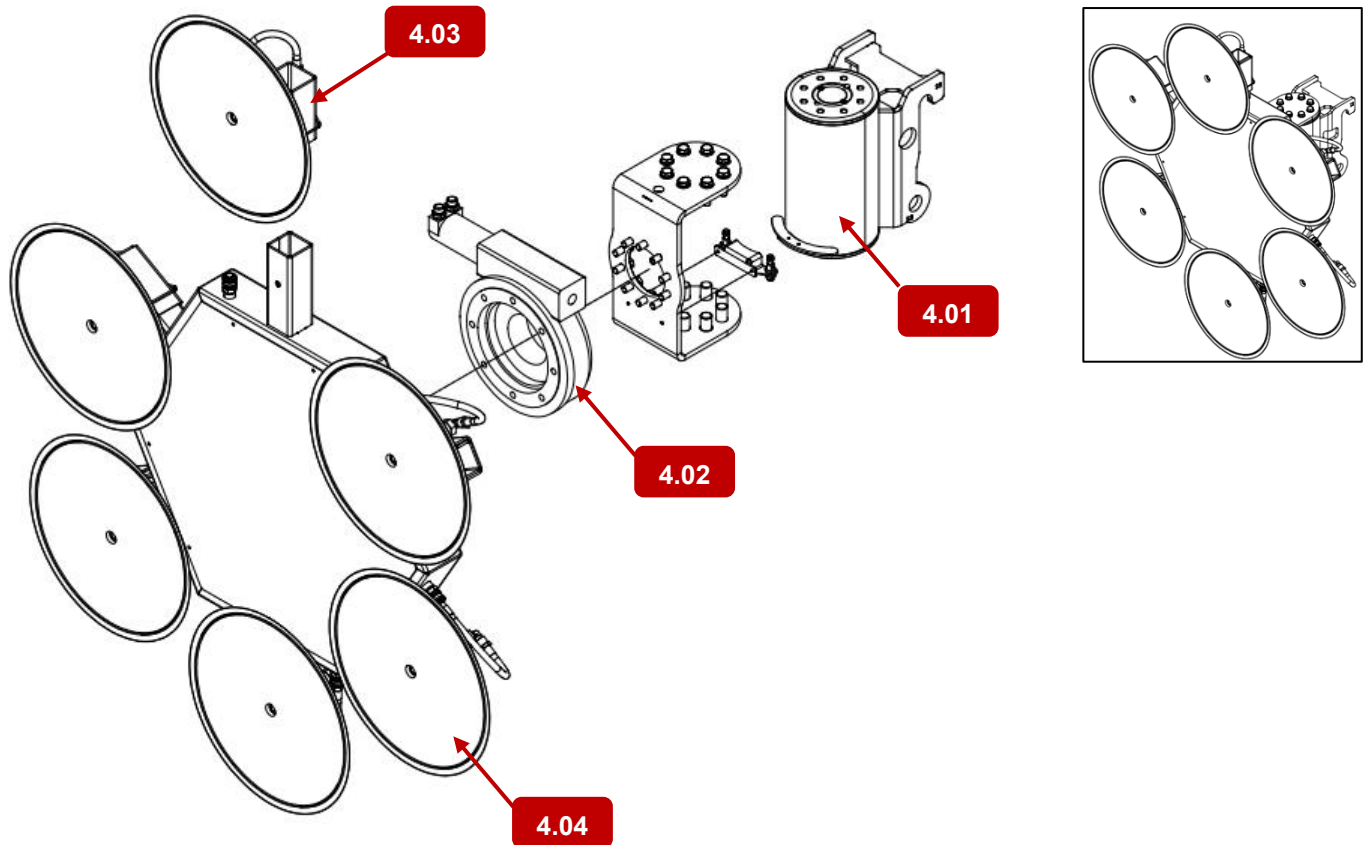

No.	Description
4.01	Turning head
4.02	Slew drive
4.03	Suction cup holder
4.04	Suction cup

### 3.2.2 Attachment overview – Hydraulic winch

Single line configuration

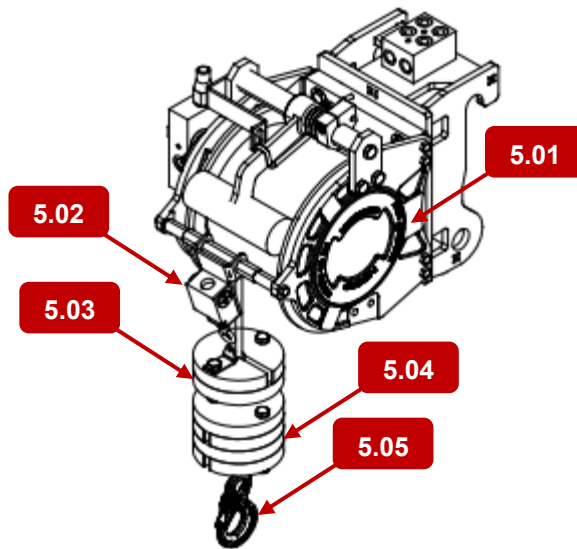

Dual line configuration

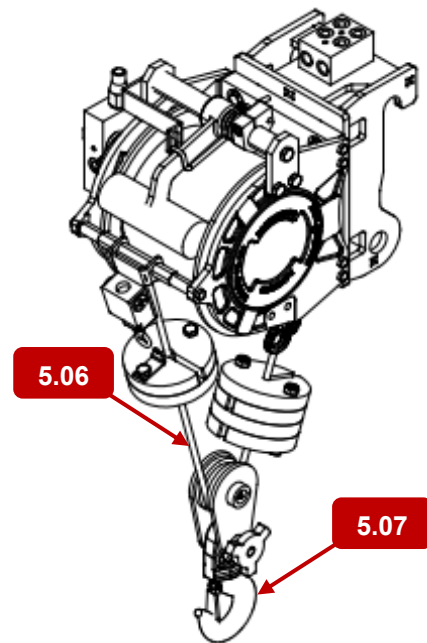

No.	Description	No.	Description
5.01	Winch	5.05	Hook
5.02	Limit switch for cable pull	5.06	Wire rope
5.03	Weight plate for top stop	5.07	Hook block (Option)
5.04	Overhaul block		

### 3.2.3 Attachment overview – Lifting hook and Fly-Jib

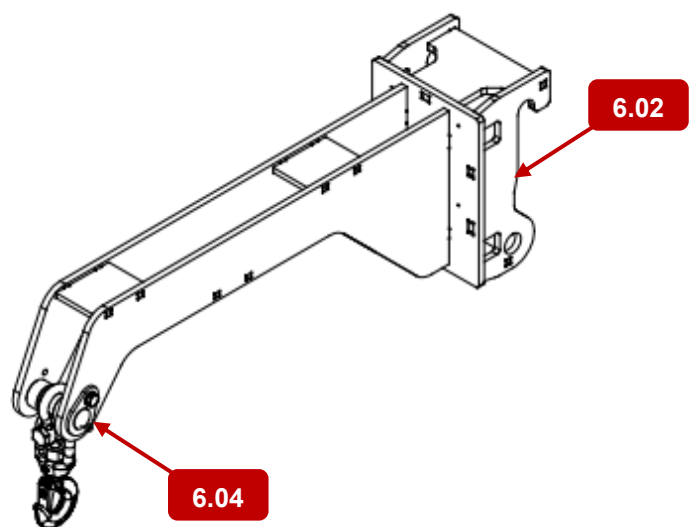
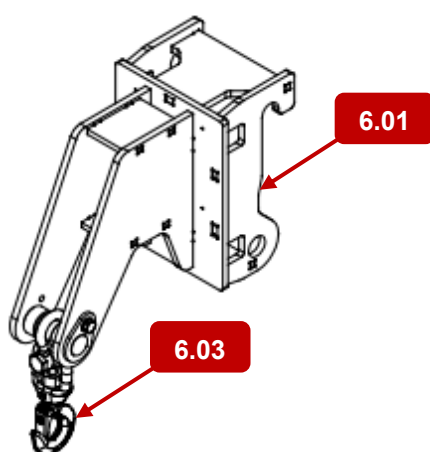

No.	Description	No.	Description
6.01	Lifting Hook	6.03	Hook
6.02	Fly-Jib	6.04	Locking pin



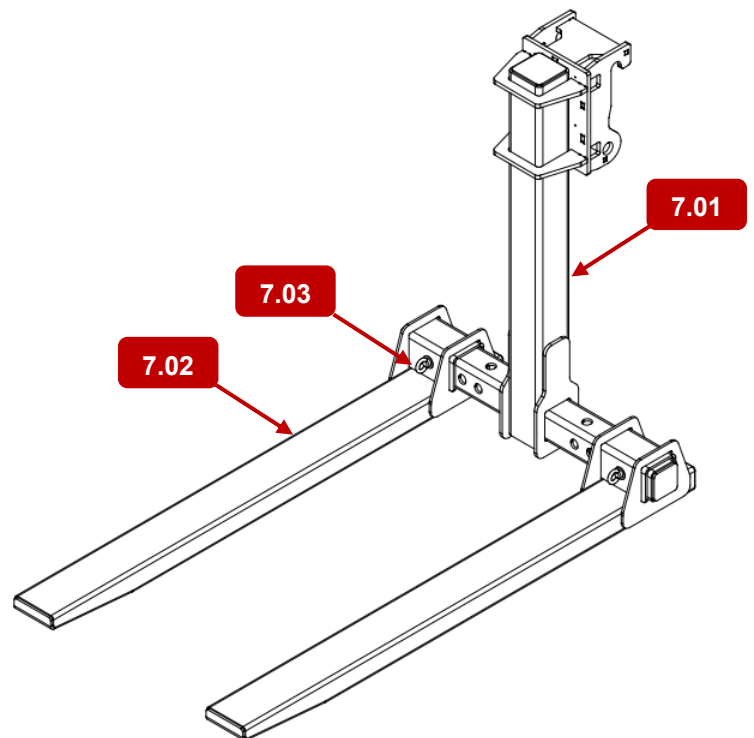

### 3.2.4 Attachment overview – Pallet fork

No.	Description
7.01	Forke frame
7.02	Single fork
7.03	Locking pin

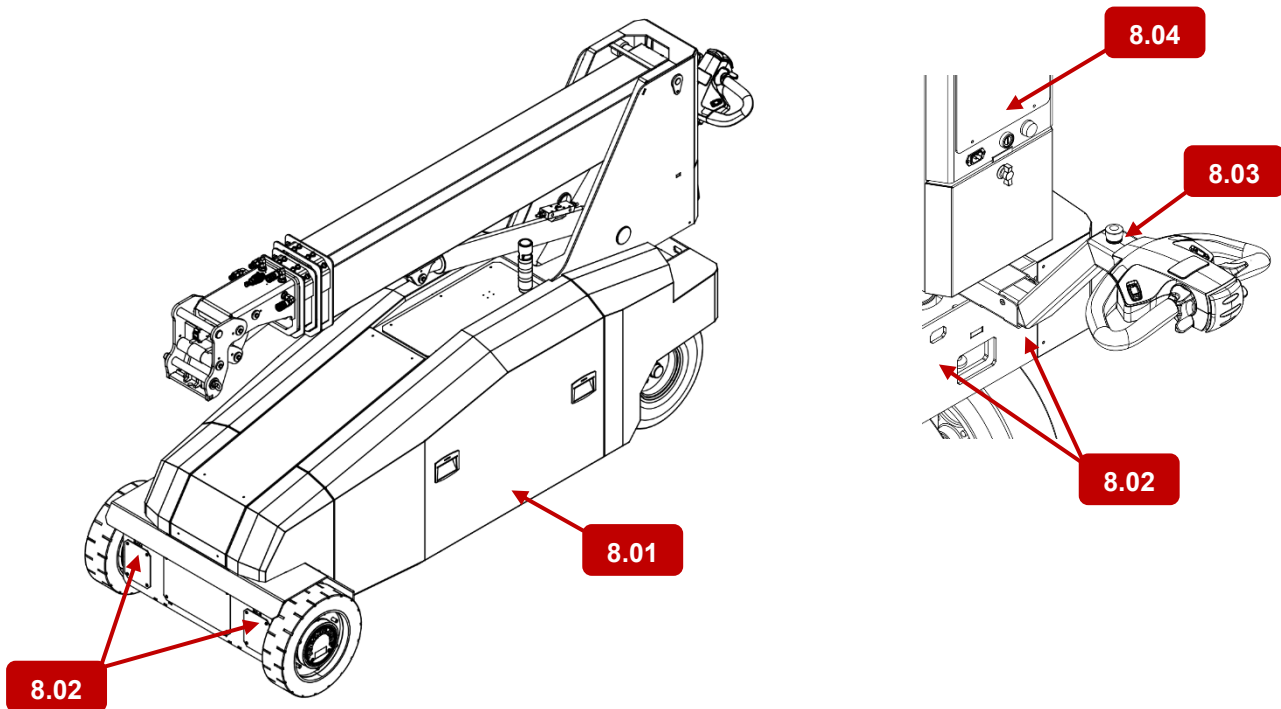

### 3.3 Label overview



No.	Description	Label
8.01	Do NOT lift under the machine.	
8.02	Lashing eye	
8.05	Emergency stop	
8.04	Power	

**! ATTENTION!** In case of illegible or unclear information and warnings on labels, load charts, etc., these must be replaced by new ones.

New labels can be ordered from Smartlift's customer service department on tel. +45 97 72 29 11 or via email: [Customerservice@smartlift.com](mailto:Customerservice@smartlift.com).

### 3.4 Technical Specifications – Machine

Machine model	SLX 2000
Self-weight	1750kg 3860lb
Length	2,78m 9,11ft
Height	1,53m 5,00ft
Width	1,01m 3,31ft
Wheelbase	2,06m 7,76ft
Driving speed, up to	5km/t 3,1mph
Operating time, up to	10 hours
Batteries (4 pcs.)	12V
Nominal system voltage	24V
Charger	110V / 230V
Charging time, minimum	8 hours
Expected service life	10 years

## 3.5 Technical Specifications – Attachments

### 3.5.1 Vacuum yoke

Attachment	Vacuum yoke
WLL	1000kg / 2200lb
Lifting height	5,85m / 19.19ft
Horizontal reach	2,70m / 8.85ft
Rotation	Endless
Turn	88°
Suction cups	6 pcs.
Suction cup size	400mm / 16in
Vacuum level	-0,53 bar / -0,62 bar
Attachment weight	150kg / 330lb

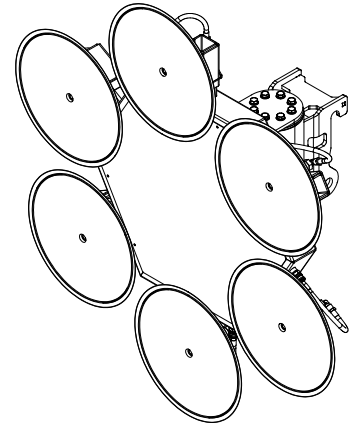

### 3.5.2 Hydraulic winch

Attachment	Hydraulic winch	
	Single line configuration	Dual line configuration
WLL	800kg / 1760lb	1500kg / 3300lb
Lifting height	4,50m / 14.76ft	4,30m / 14.10ft
Horizontal reach	2,60m / 8.53ft	
Wire rope, non-rotating	50m / 54.68yd	
Wire rope diameter	8mm / 5/16in	
Attachment weight	70kg / 154lb	75kg / 165lb

**Single line configuration**

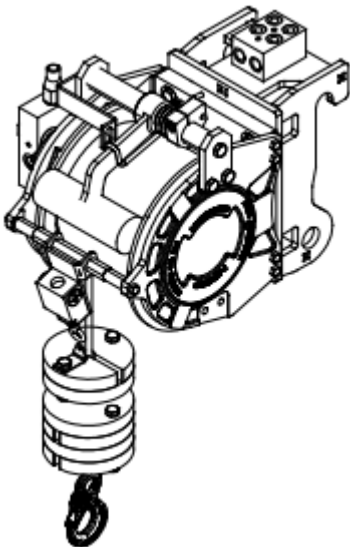

**Dual line configuration**

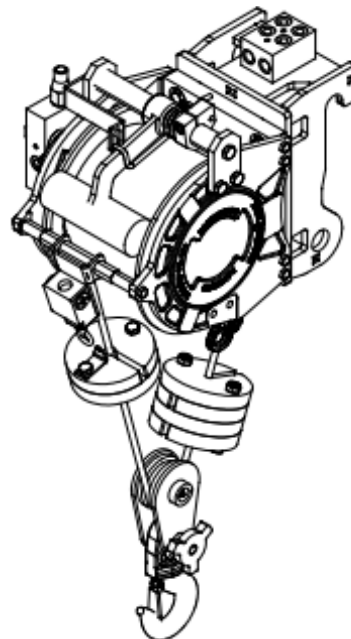

**Hook block**

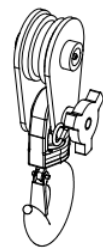

### 3.5.3 Lifting hook

Attachment	Lifting hook
WLL	1400kg / 3085lb
Lifting height	5,35m / 17.55ft
Horizontal reach	2,50m / 8.20ft
Effective length	320mm / 12.60in
Attachment weight	20kg / 44lb

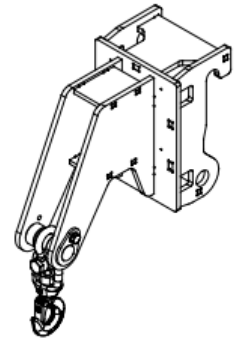

### 3.5.4 Fly-Jib

Attachment	Fly-Jib
WLL	800kg / 1765lb
Lifting height	5,85m / 19.19ft
Horizontal reach	3,00m / 9.85ft
Effective length	800mm / 2.62ft
Attachment weight	30kg / 66lb

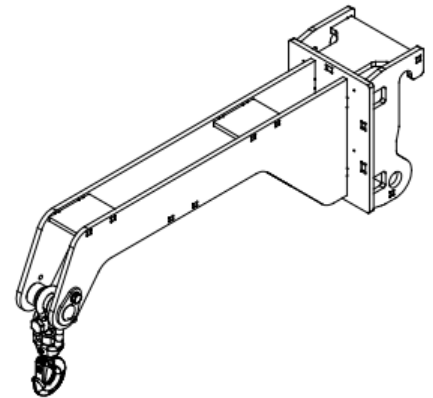

### 3.5.5 Pallet fork

Attachment	Pallet fork
WLL	800kg / 1765lb
Lifting height	4,35m / 14.27ft
Horizontal reach	3,00m / 9.85ft
Fork length	1,20m / 3.94ft
Fork width	0,79m / 2.60ft
Transport length	1,41m / 4.64ft
Transport height	300mm / 11.80in
Attachment weight	80kg / 176lb

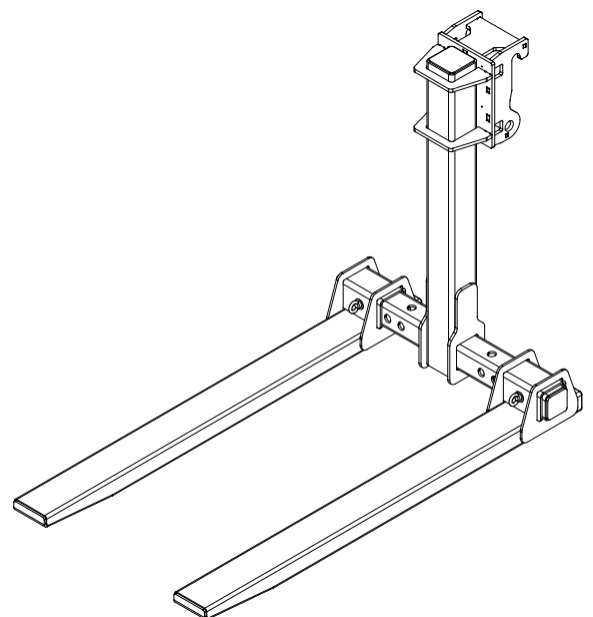

### 3.6 Operating limits

It is the user's responsibility to be alert and vigilant in the environment in which the machine is used. The user must be aware of everything that could impact safety of both machine and people.

All operating limits in this section apply to the machine, including all s any attachments and accessories.

See additional operating limits for each attachment in section **3.7 Operating limits – Attachments**.

#### 3.6.1 Lifting capacity

The lifting capacity of the machine depends on which attachment is used with the machine. See section **3.5 Technical Specifications – Attachments** and **8.4 Load chart**.

#### 3.6.2 Temperature and humidity

Permissible temperature range	From -20 C° to 40 C°
Permissible relative humidity (Non-condensing)	From 20 % to 80 %

#### 3.6.3 Lighting

Workspace	Min 200 lux
Repair and maintenance work	Min 500 lux

#### 3.6.4 Surface

When using the machine, a solid surface is important. This applies during both the driving and handling of objects.

**⚠ WARNING! Always assess the surface before using the machine. Soft or unstable surfaces may result in potential tipping and pose a serious safety hazard to the operator and others nearby!**

#### 3.6.5 Slope – Location of the user and other persons

When driving on a slope, the user must be aware of their own and others' positions in relation to the machine.

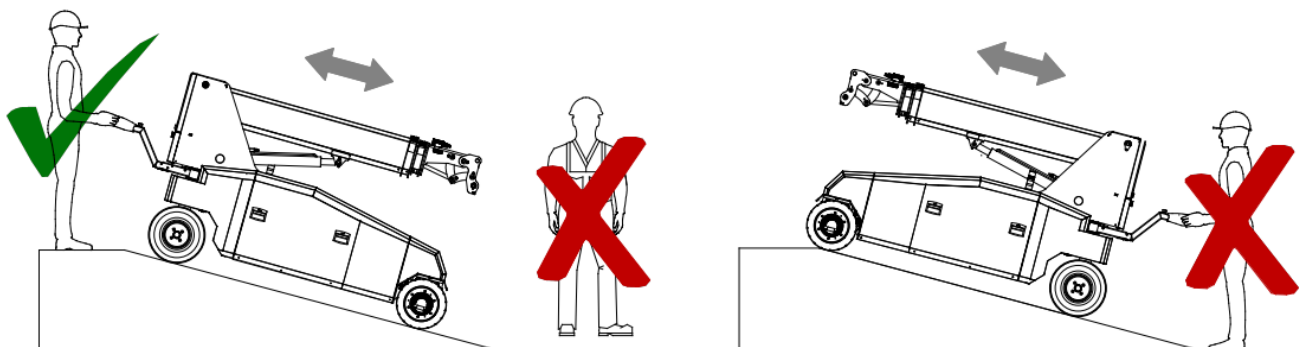

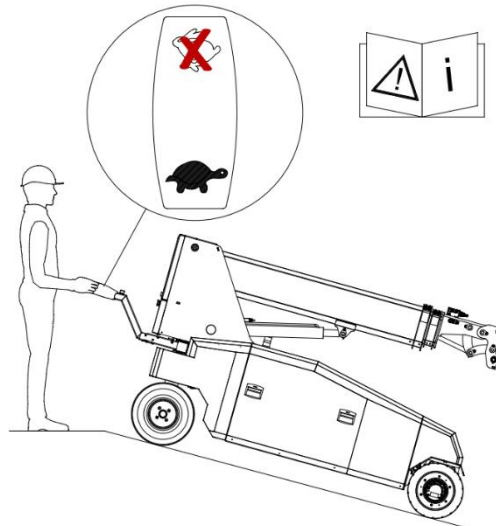

**⚠ WARNING!**

- Never stand below the machine when it is moving up or down a slope!
- Always drive at low speed and exercise caution when going down a slope!

### 3.6.6 Slope – Parking

When parking the machine across a slope, the steering wheels must be aligned with the longitudinal direction of the machine  $\pm 45^\circ$ .

**⚠ WARNING!** If the steering wheels are turned to the sides this could cause the machine to start rolling down the slope!

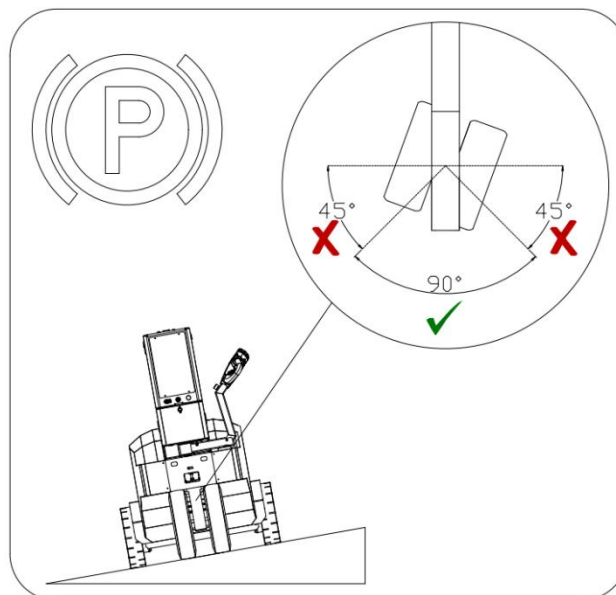

### 3.6.7 Slope – Driving with and without load

When driving a loaded machine on a slope, always keep the load as close to the ground as possible.

**⚠ WARNING!** The shape and weight of the load, the speed of the machine, and weather conditions all affect the stability of the machine when driving on a slope. Therefore, always assess whether moving it is sensible!

Issued by:	Date:	Approved by:	Document name.:	Page
TST	24/03/2026	MR	USER MANUAL - SLX 2000 EN 01	20 of 51

## 3.7 Operating limits – Attachments

### 3.7.1 Lifting capacity

The lifting capacity of the machine depends on which attachment is used with the machine. See section 8.4 Load chart.

**⚠ WARNING! Wait and verify that sufficient vacuum has been built up and that the vacuum pumps have stopped before performing any lifting!**

### 3.7.2 Vacuum yoke

#### 3.7.2.1 Suction cups

**⚠ WARNING! Never use the vacuum yoke attachment with fewer than 4 suction cups!**

**⚠ ATTENTION! Any change to the size, type or number of the suction cups will reduce WLL!**

**⚠ ATTENTION! The suction cups must always be evenly distributed between the red and blue vacuum circuits!**

Size	Number	WLL
400 mm /	6 pcs.	1000 kg /
400 mm /	4 pcs.	600 kg / 1320
300 mm / 12	6 pcs.	520 kg / 1150
300 mm / 12	4 pcs.	350 kg / 770

#### 3.7.2.2 Materials

By default, the yoke is equipped with suction cups, which are intended for handling flat and smooth objects such as glass, plastic sheets etc.

**⚠ WARNING! Never use the machine to lift dirty, dusty, wet or greasy items!**

**⚠ WARNING! Never use the machine to lift items that are not airtight!**

#### 3.7.2.3 Height above sea level

When working with the machine at heights of more than 1000 m (3280 ft) above sea level, the table below can be used as a guideline.

Height above sea level		Vacuum level
Meters	Feet	Max. possible in height
< 1000 m	< 3280 ft	100 %
1000 m	3280 ft	87 %
2000 m	6560 ft	75 %
3000 m	9840 ft	65 %
4000 m	13120 ft	56 %

Example when working at height:

- Machine: SLX 2000 with vacuum yoke attachment WLL 1000 kg (2200 lb)
- Height above sea level: 2000 m (6560 ft)
- Max. possible vacuum level at height: 75 %

$$WLL_{height} = WLL_{vacuum\ yoke\ attachment} * Max.\ possible\ vacuum\ level\ at\ height$$

$$WLL_{height} = 1000\ kg\ (2200\ lb) * 0,75 = 750\ kg\ (1650\ lb)$$

### 3.7.3 Hydraulic winch

**!** ATTENTION! Drive with great caution (swinging load)!

**!** ATTENTION! Keep the load close to the ground while driving!

**!** WARNING! Always keep at least 4 wraps of wire rope on the drum for safety reasons!

**!** ATTENTION! For the hydraulic winch attachment, the range of the tilt function is restricted by the inclinometer for safety reasons!

### 3.7.4 Lifting hook and Fly-Jib

**!** ATTENTION! Drive with great caution (swinging load)!

**!** ATTENTION! Keep the load close to the ground while driving!

### 3.7.5 Pallet forks

**!** WARNING! The load must be evenly distributed on the pallet forks!

**!** WARNING! Always keep the pallet forks in horizontal position!

**!** ATTENTION! For the pallet fork attachment, the range of the tilt function is restricted by the inclinometer for safety reasons!

Issued by:	Date:	Approved by:	Document name.:	Page
TST	24/03/2026	MR	USER MANUAL - SLX 2000 EN 01	22 of 51

## 4 Operating

This section describes which basic elements it is important to understand in order to maintain a high level of safety when using the machine. This section describes the steps it is necessary to know before, during and after use of the machine.

**! ATTENTION! The user is always responsible for avoiding irresponsible operating of the machine!**

### 4.1 Before operating

**! WARNING!**

- **Do not use a knife to remove the packaging materials!**
- **Never use the machine if visible damage or defects have been identified!**

Before operating the machine, it must be inspected for visible damage to the i.e. wires, and the vital parts of the steel structure. In addition, the machine must be inspected for any defects. If any damage or defects are identified, these must be repaired before using the machine.

Before operating the machine, the user must always conduct a thorough assessment of the machine's task, including, as a minimum:

- Operating limits (See section **3.6 Operating limits**)
- Load chart (See section **8.4 Load chart**)
- Battery level

### 4.2 Operating in general

The following describes a typical procedure for using the machine. For a more detailed description of functions, buttons, etc., see section **4.7 Functional overview**.

### 4.3 Driving the machine with the control handle:

1. Turn on the machine at the On/Off key switch and wait for the green light.
2. Check the battery level.
3. Turn on the control handle at the On/Off button.
4. Drive the machine with the control handle.
5. Drive the machine to the attachment.
6. Get the remote control from the rear storage compartment on the machine.
7. Turn on the remote control by first deactivating the off button and activating the On button.
8. Remove the locking shaft and linchpin from the quick change.
9. Pick up the attachment with the quick change by using the move functions on the remote control.
10. Lock the attachment in place with the locking shaft and the linchpin.
11. Connect hydraulic hoses and wires for the attachment.
12. Press the enter button by the remote control display when the machine has identified the attachment.

**! ATTENTION! This will enable attachment specific functions!**

13. Use the attachment according to the latest edition of the attachment specific user manual.
14. When removing the attachment, reverse steps 11, 10, 9, and 8 in this order.
15. When the work with the machine is completed:
  - Turn of the remote control at the off button.
  - Turn the machine off at the main switch.
  - Charge the machine at the end of the working day.

Issued by:	Date:	Approved by:	Document name.:	Page
TST	24/03/2026	MR	USER MANUAL - SLX 2000 EN 01	23 of 51

#### 4.4 Driving the machine with the remote control (Option):

1. Turn on the machine at the ON/OFF key switch and wait for the green light.
2. Check the battery level.
3. Get the remote control from the rear storage compartment on the machine.
4. Turn on the remote control by first deactivating the off button and activating the ON button.
5. Switch from “Move mode” to “Drive mode” on the remote control.

**! ATTENTION! An audible signal will confirm the change between “Move mode” and “Drive mode”!**

6. Use levers 1 and 6 on the remote control to drive the machine.
7. Drive the machine to the attachment.
8. Switch from “Drive mode” to “Move mode” on the remote control.
9. Remove the locking shaft and linchpin from the quick change
10. Attach the attachment with the machine quick change.
11. Lock the attachment in place with the locking shaft and the linchpin.
12. Connect hydraulic hoses and connect the electrical plug for the attachment.
13. Press the enter button by the remote control display when the machine has recognized the correct attachment.

**! ATTENTION! This will enable attachment specific functions!**

14. Use the attachment according to the latest edition of this user manual.
15. When removing the attachment, reverse steps 11, 10, 9, and 8 in this order.
16. When the work with the machine is completed:
  - Turn of the remote control at the off button.
  - Turn the machine off at the main switch.
  - Charge the machine at the end of the working day.

Issued by:	Date:	Approved by:	Document name.:	Page
TST	24/03/2026	MR	USER MANUAL - SLX 2000 EN 01	24 of 51

## 4.5 Signals

A light tower (red, yellow and green) with a built-in acoustic alarm is mounted on the machine, which gives signals about the status of the machine. The table describes the signals:

Tower light signals				
State	Red	Yellow	Green	Alarm
Machine is switched off	-	-	-	-
Machine is inactive	-	-	ON	-
Machine is active	-	-	Flashing	-
Machine is starting up	-	ON	-	-
Machine reports an error	-	ON	-	-
Machine is at 90% load	-	Flashing	-	-
Machine is charging	-	Flashing	-	-
Critically low vacuum level during lifting	ON	-	-	ON
Machine reports a critical error	ON	-	-	-
Emergency stop is activated	ON	-	-	-
Machine is locked via Tracker GPS/GSM	ON	-	-	ON
Machine is at 100% load	Flashing	-	-	2 bp/m
Recovery mode is activated	Flashing	Flashing	-	4 bp
Battery voltage too low	Flashing	Flashing	Flashing	-

## 4.6 After operating

### 4.6.1 Machine batteries

To ensure optimum preservation of battery capacity, use the following charging pattern.

- Connect the charger for at least 8 consecutive hours before using the machine.
- Connect the charger permanently when storing the machine. This maintains the batteries at a constant rate.

#### ! ATTENTION!

- **Charging must take place somewhere with good ventilation!**
- **Charging can never take place in a location where there are sparks, flames or smoking!**
- **The machine must be switched off at the main switch before charging!**
- **If the charger is connected for a period which is shorter than recommended, over time, the battery capacity will be reduced permanently!**
- **If the machine is stored for a long period of time without the charger being connected to a power supply, the battery capacity will be reduced permanently!**
- **The machine must be charged before the voltage on the batteries falls below 22V (while operating), otherwise the batteries will be permanently damaged!**
- **The machine cannot be used and charged at the same time. After disconnecting the charging plug, it can take up to 30 seconds before the machine can be used.**

#### 4.6.1.1 Machine charger

See location on the charger in section 4.7.1 Power.

#### ! ATTENTION! The charging “Mode” must be set to COLD/AGM!

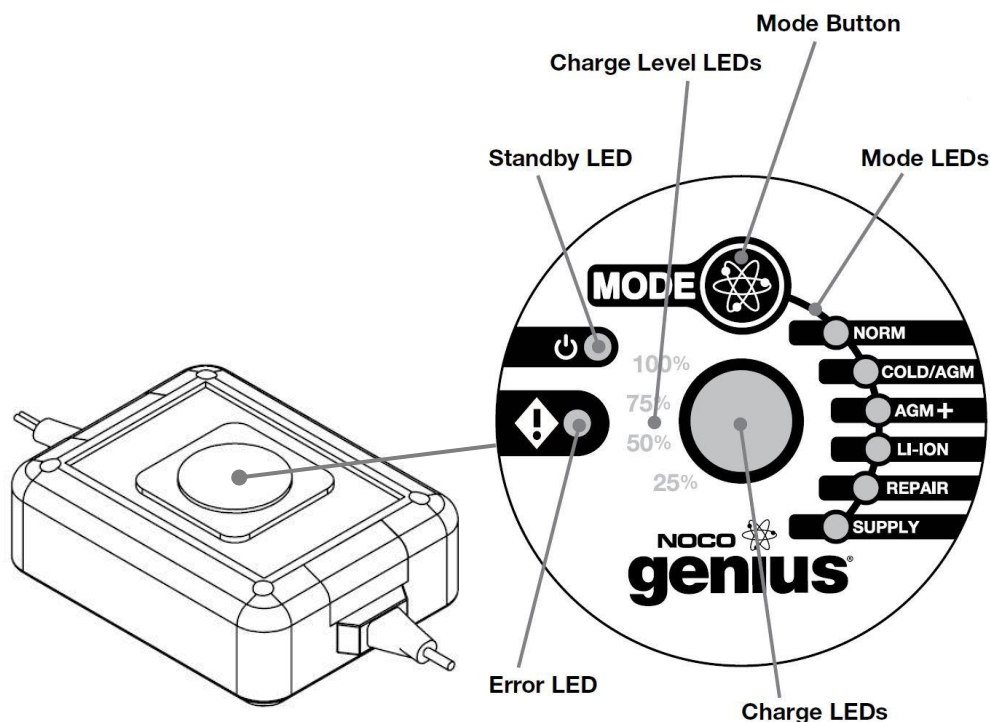

Issued by:	Date:	Approved by:	Document name.:	Page
TST	24/03/2026	MR	USER MANUAL - SLX 2000 EN 01	26 of 51



Charge Level LEDs and Charge LEDs	
Charge Level LEDs	Charge LEDs
25% Charge Level LED illuminates when the battery is between 0% og 25% charged.	RED LEDs “spin” indicating that the batteries are charging.
50% Charge Level LED illuminates when the battery is between 25% og 50% charged.	
75% Charge Level LED illuminates when the battery is between 50% og 75% charged.	
100% Charge Level LED illuminates when the battery is between 75% og 100% charged.	GREEN LED illuminates indicating that the battery is fully charged.

Error LED and Standby LED		
LEDs	Cause	Solution
Standby LED: 1 ORANGE flash Error LED: Illuminates RED	The battery will not hold charge.	Contact your nearest dealer or Smartlift Customer Service at tel. +45 97 72 29 11 or email: <a href="mailto:customerservice@smartlift.com">customerservice@smartlift.com</a> .
Standby LED: 2 ORANGE flashes Error LED: Illuminates RED	The battery might be short-circuited.	Contact your nearest dealer or Smartlift Customer Service at tel. +45 97 72 29 11 or email: <a href="mailto:customerservice@smartlift.com">customerservice@smartlift.com</a> .
Standby LED: 3 ORANGE flashes Error LED: Illuminates RED	The battery voltage is too high for the selected “Mode”.	Change “Mode” to “COLD/AGM”.
Standby LED: 4 ORANGE flashes Error LED: Illuminates RED	Abnormal AC grid power: VAC<85V or >250V. Frequency: <45 or >65Hz	
Error LED: Illuminates RED	Reversed polarity.	Contact your nearest dealer or Smartlift Customer Service at tel. +45 97 72 29 11 or email: <a href="mailto:customerservice@smartlift.com">customerservice@smartlift.com</a> .
Standby LED: Illuminates ORANGE	The battery voltage is too low for the charger to detect.	Check that “Mode” is set to “COLD/AGM”. Change “Mode” to “Supply Mode” for maximum 15-20 minutes. The switch back to “COLD/AGM” again. Contact your nearest dealer or Smartlift Customer Service at tel. +45 97 72 29 11 or email: <a href="mailto:customerservice@smartlift.com">customerservice@smartlift.com</a> .

## 4.6.2 Remote control batteries

To ensure optimum preservation of battery capacity, use the following charging pattern:

- Always keep the extra battery in the charger. See location on the charger in section **4.7.1 Power**.
  - The charging cycle is approx. 3 hours.
- Place one battery in the remote control.
- Replace the batteries if necessary and at the end of the workday.

### 4.6.2.1 Remote control charger

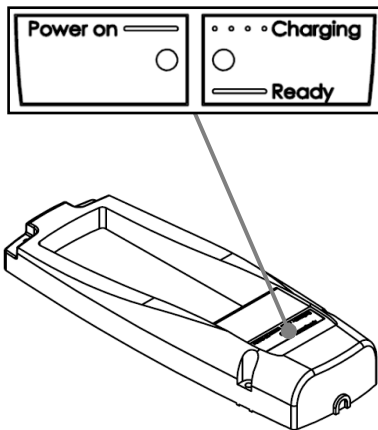

Power LED and Charging LED	
LED	Description
Power LED: Illuminates RED	The charger is connected
Charging LED: Flashing GREEN	Charging battery
Charging LED: Illuminates GREEN	Fully charged / Storage-mode

## 4.7 Functional overview

### 4.7.1 Power and control handle

No.	Description	Function
9.01	Charging plug	Connecting the mains socket for charging (230V/110V)
9.02	On/Off key switch	Turn the machine on/off
9.03	Charging indicator	Illuminates when the machine is charging
9.04	Rear storage compartment	Contains remote control, charger for remote control battery and Charging cable.
9.05	Emergency stop	Disables all function except vacuum
9.06	On/off button for propulsion	On: Propulsion can be activated Off: Propulsion is interrupted
9.07	Safety switch	"Belly button" Ensures that the risk of being squeezed between the machine and an obstacle is minimized.
9.08	Speed and direction regulator	Used for regulating travel speed from 0 to max
9.09	Horn switch	Signals when activated
9.10	High/low travel speed	High: High max Speed Low: Low max Speed

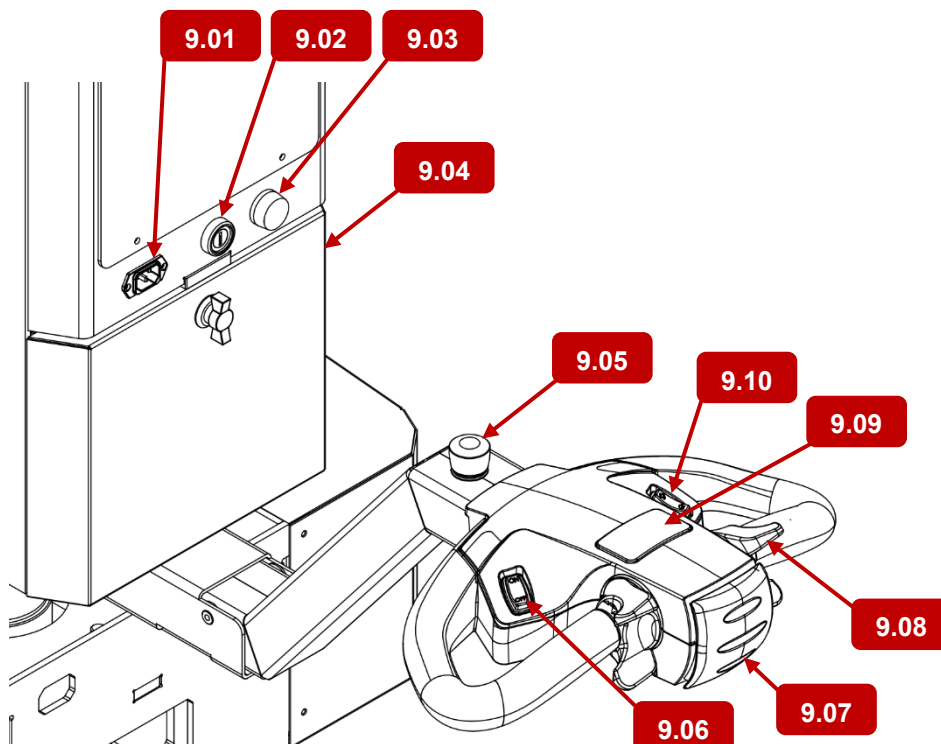

## 4.7.2 Remote control

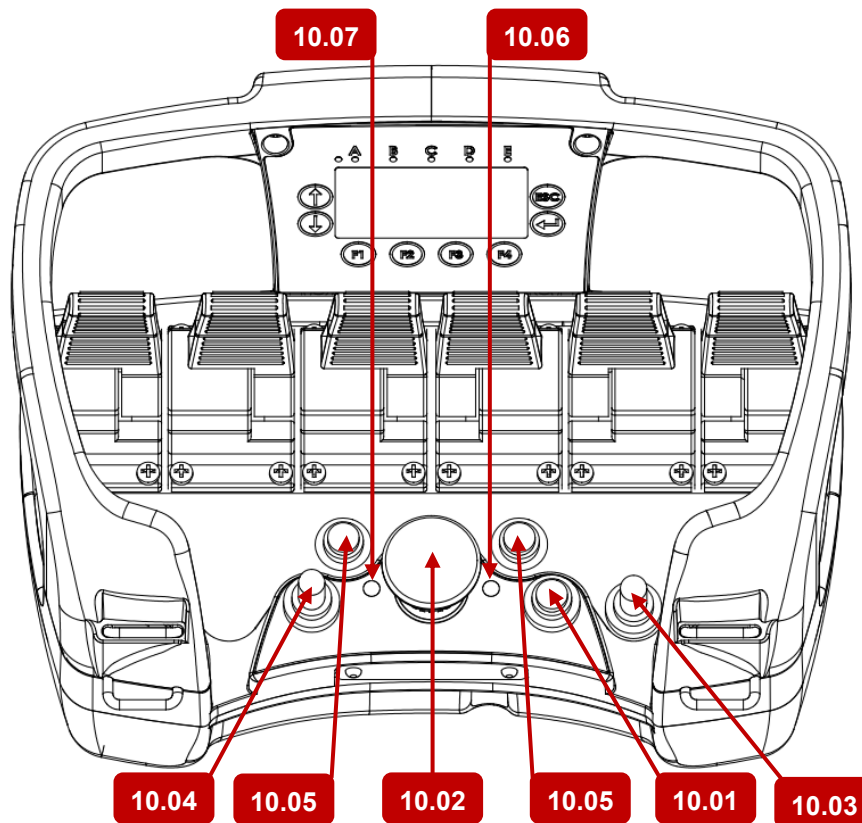

No.	Description	Function
10.01	On / Reset	Turns on the remote control. Reset by holding down the button for approx. 5 sec.
10.02	Off	Disables all hydraulic functions.
10.03	Move mode / Drive mode	Switches between modes: Move mode: Use of the machine functions Drive mode: Drive the machine with the remote control
10.04	Speed limiter Machine functions	Left: Low maximum speed. Right: High maximum speed.
10.05	Attachment specific On / Off Vacuum	Activating the vacuum: Push one of the buttons until the audio signal sounds. Deactivating the vacuum: Push and hold down both buttons until the audio signal stop.
10.06	LED	Illuminates RED when the remote control is turned on.
10.07	LED	Illuminates RED if there is no connection to the machine. Flashes GREEN if Low speed is activated.

### 4.7.3 Remote control – Move mode

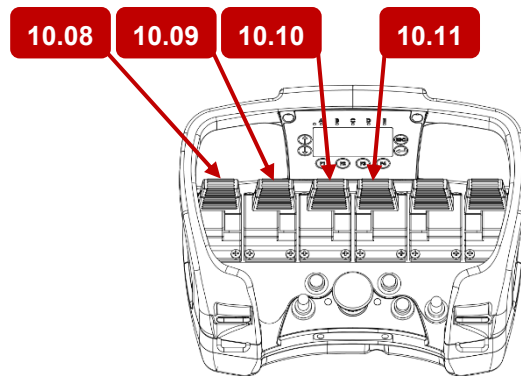

No.	Description	Function
10.08	Move mode Sideshift	Forward: The machine shifts to the right Backward: The machine shifts to the left

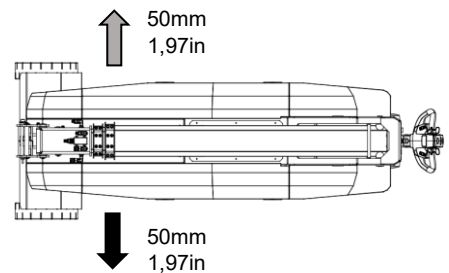

No.	Description	Function
10.09	Move mode Raise / lower	Forward: The boom is lowered Backward: The boom is raised

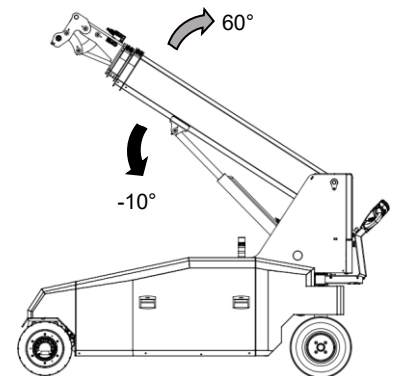

No.	Description	Function
10.10	Move mode Extend / retract	Forward: The boom is extended Backward: The boom retracted

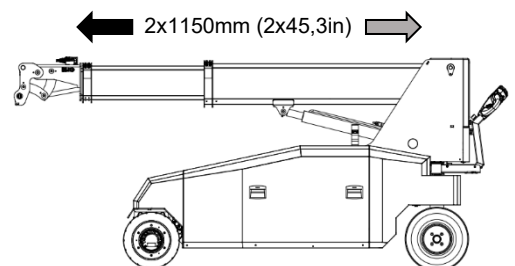

No.	Description	Function
10.11	Move mode Tilt	Forward: The vacuum yoke is tilted forward. Backward: The vacuum yoke is tilted backwards.

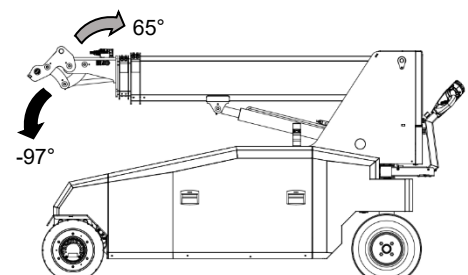

#### 4.7.4 Remote control – Move mode – Attachment Dependent

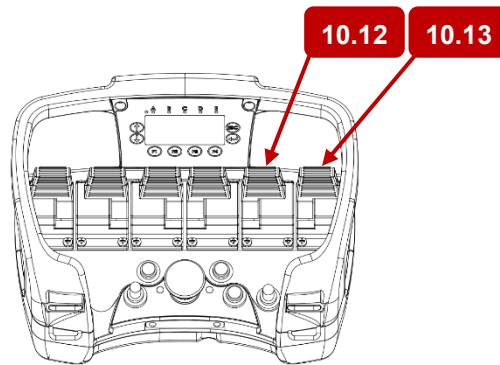

No.	Description	Function
10.12	Move mode Vacuum yoke Rotation	Forward: The vacuum yoke is rotated clockwise. Backward: The vacuum yoke is rotated counterclockwise.

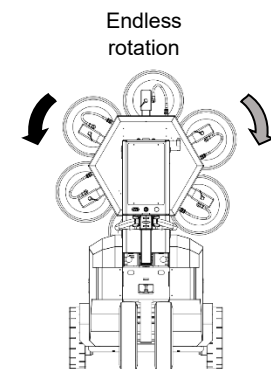

No.	Description	Function
10.13	Move mode Vacuum yoke Yaw	Forward: The vacuum yoke turns to the right side Backward: The vacuum yoke turns to the left side
	Move mode Hydraulic winch	Forward: The winch hook is lowered Backward: The winch hook is raised

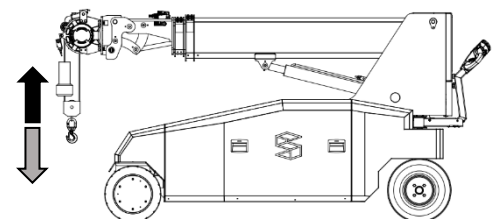
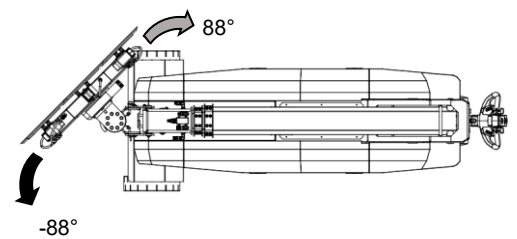

### 4.7.5 Remote control – Drive mode

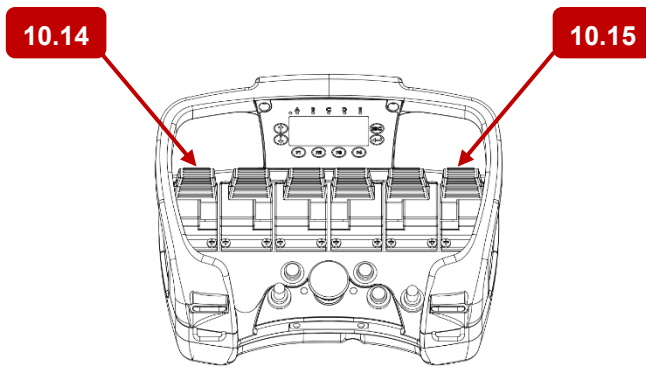

No.	Description	Function
10.14	Drive mode Propulsion	Forward: The front wheels drive forward. Backward: The front wheels drive backward.

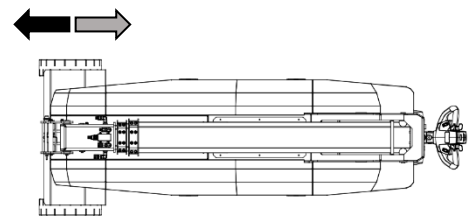

No.	Description	Function
10.15	Drive mode Turn	Forward: The rear wheel turn to the right. Backward: The rear wheels turn to the left.

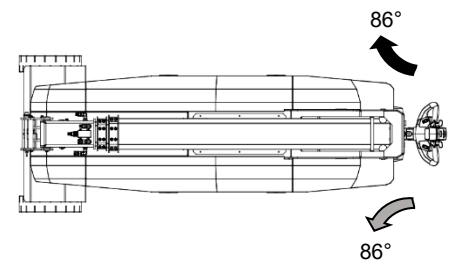

### 4.7.6 Remote control – Display

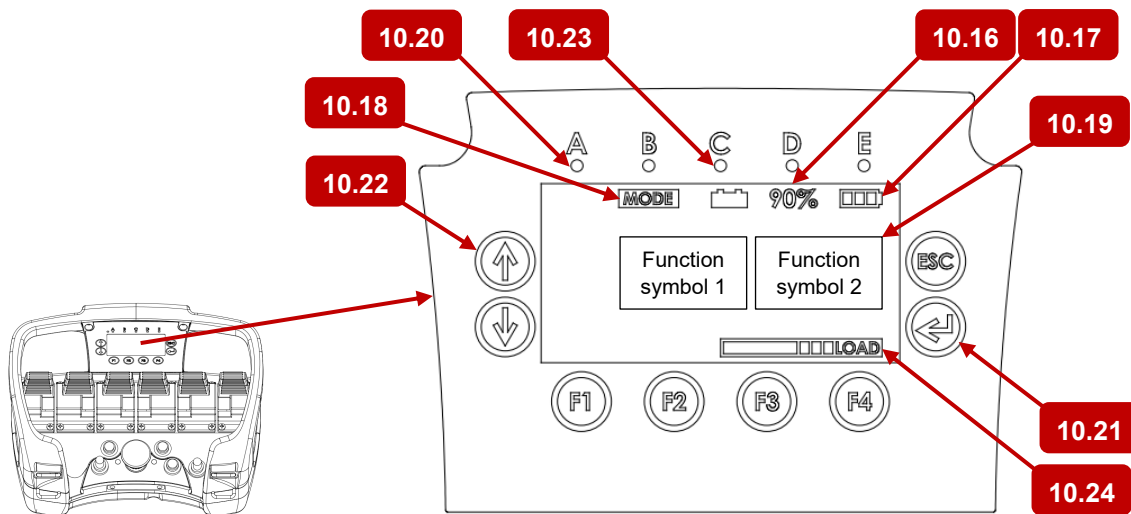

No.	Description	Function
10.16	Battery indicator - machine	Indicates the machine's battery level in percent
10.17	Battery indicator - remote control	Indicates the battery level of the remote control
10.18	Mode indicator – Move / Drive	Indicates whether the remote control uses the move or drive mode.
10.19	Function symbol 1+2	When 1 og 2 function is used, symbols will appear showing which function and which direction.
10.20	GREEN LED (A)	Flashing when no attachment is connected. Illuminates when an attachment has been recognized and confirmed.
10.21	Enter button	When an attachment is mounted, the remote control will recognize it and prompt for confirmation of which attachment has been installed.
10.22	Arrow Up	<p>Activate / Deactivate the inclinometer.</p> <p>When activated the position of the inclinometer is saved and the machine will keep this position when the raise / lower function or the extend / retract function is used.</p> <p>If the tilt function is activated, the saved position will be changed.</p>
10.23	YELLOW LED (C)	Flashing when the inclinometer function is activated.
10.24	Load level	Indicates how much of the lifting capacity is used.

### 4.7.7 Remote control – Display – Attachment – Vacuum yoke

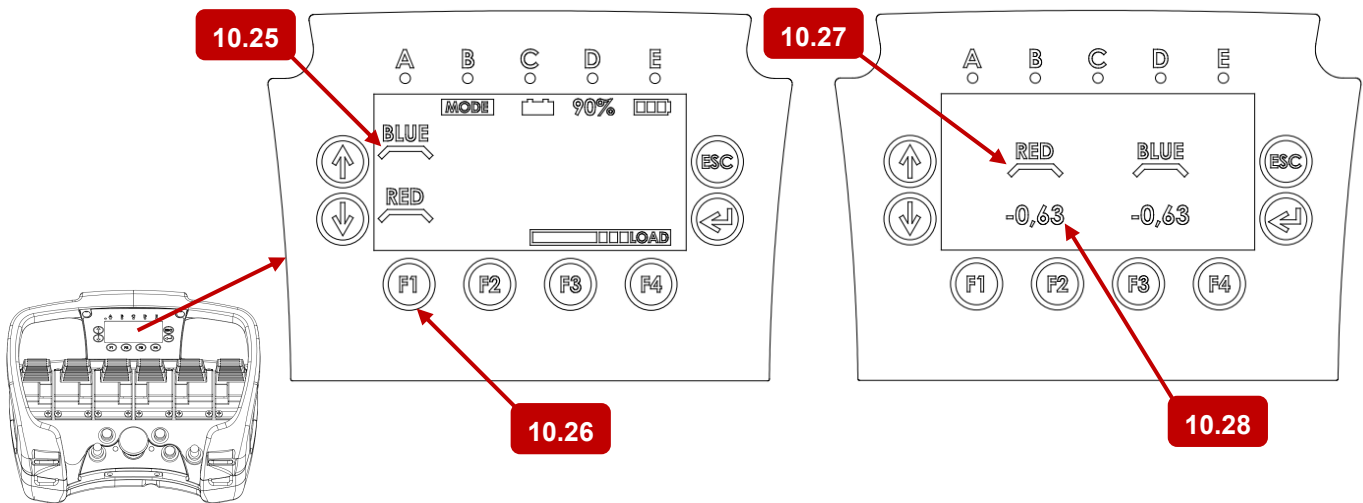

No.	Description	Function
10.25	Vacuum symbols	Visualizes the direction of airflow for blue and red vacuum circuit.
10.26	F1 (Vacuum page)	Turn to display page 2 with vacuum information.
10.27	Vacuum symbols	Visualizes the direction of airflow for blue and red vacuum circuit.
10.28	Vacuum level	Displays the vacuum level for blue and red vacuum circuit.

## 4.8 Attachment mounting instruction

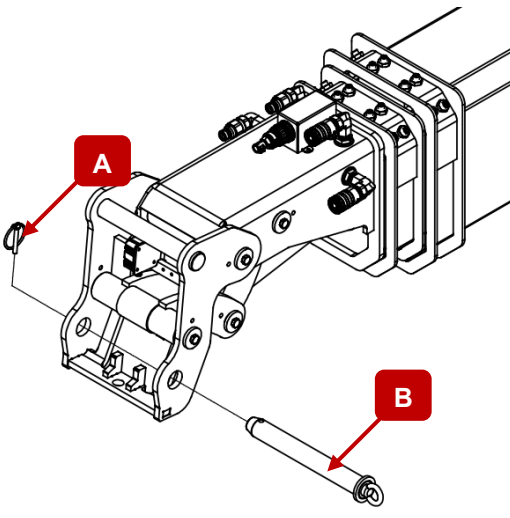
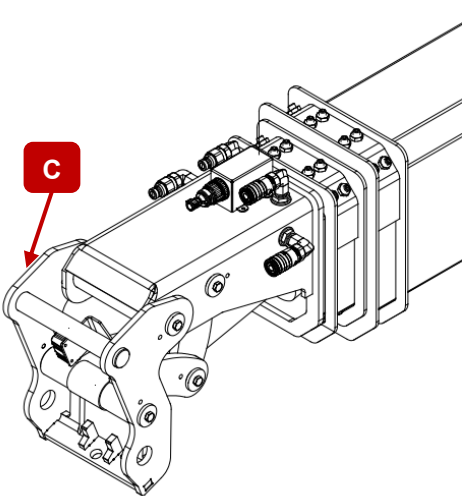
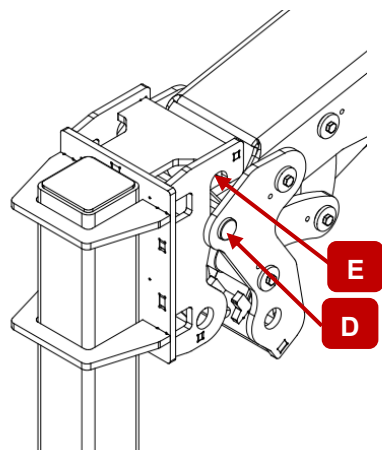
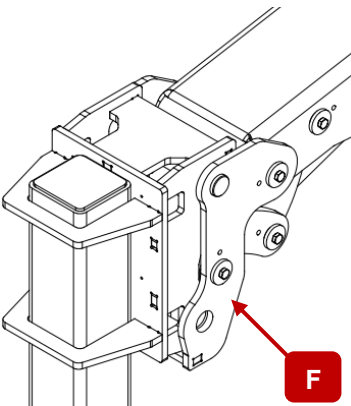
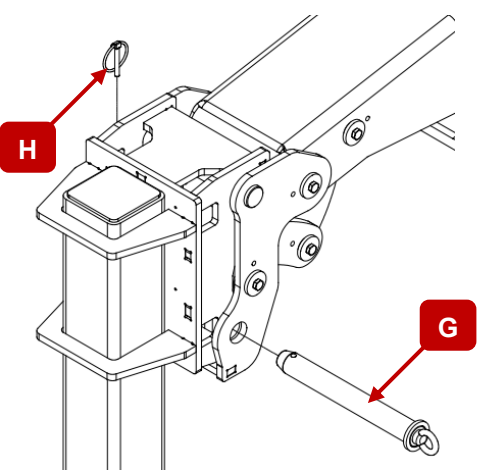
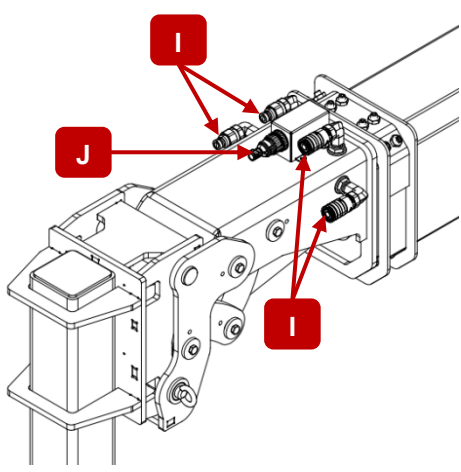
	
<p>Step 1 – Remove the Linchpin (A) followed by the locking shaft (B).</p>	<p>Step 2 – Tilt the quick change (C) forward.</p>
	
<p>Step 3 – Guide the top bar of the quick change (D) into the attachment hooks (E).</p>	<p>Step 4 – Tilt the quick change backward (F).</p>
	
<p>Step 5 – Secure the attachment in place using the locking shaft (G), followed by the linchpin (H).</p>	<p>Step 6 – Connect any hydraulic hoses (I) and the cable (J)</p>

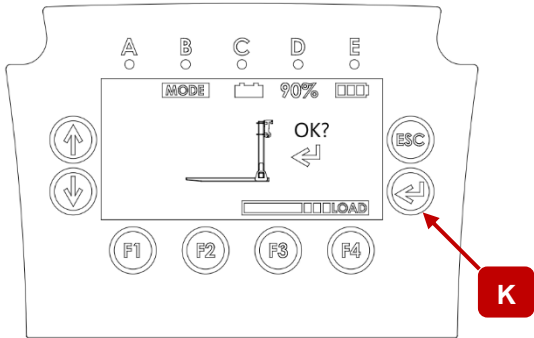
	
<p>Step 7 – When an attachment is mounted, the remote control will recognize it and prompt for confirmation of which attachment has been installed. Press Enter to confirm (K).</p>	

## 5 Storage and transport

### 5.1 Storage

If the machine needs to be stored, storage must be done under the following conditions to preserve the machine's condition and functional capacity:

- Indoor
- Dry
- With good ventilation

How to store:

- Turn off the main switch.
- Connect the charger so that the batteries are constantly charged and maintained. See section **4.7.1 Power**.

### 5.2 Transport

When transporting the machine, it is recommended that a van, machine trailer, flatbed truck or similar with sufficient load capacity is used. Find the weight of the machine in section **3.4 Technical Specifications**. See location of lashing eyes in section **3.3 Label overview**.

A method for secure fastening of the machine:

- Turn off the main switch.
- Strap the machine in place using the lashing eyes.
- Protect the machine from rain, moisture and dust.

Issued by:	Date:	Approved by:	Document name.:	Page
TST	24/03/2026	MR	USER MANUAL - SLX 2000 EN 01	37 of 51

## 6 Maintenance and troubleshooting

### 6.1 Overview of service, maintenance and lubrication intervals

No.	Annually			In addition to the dates listed, some components are subjected to ongoing wear and must therefore be replaced if necessary.
	↓	Monthly interval		
		↓	Daily	
<b>1.0</b>				<b>Log and labelling</b>
1.1	X	12	X	The user manual is accessible and easy to understand. Receipt of new user manual. State machine type and serial number when ordering.
1.2	X	12		Labels on the machine. Check that all labels are visible and intact. Defective labels must be replaced if necessary. Load chart, attention/warning stickers etc.
<b>2.0</b>				<b>Battery and charger</b>
2.1	X	12	X	Battery. Check the capacity of the batteries (minimum 24V on fully charged batteries).
	X	12		Battery. Battery indicator. Replace the batteries if the voltmeter reads less than 24 volts when the batteries are fully charged. The terminals must be lubricated (A).
2.2	X	12		Charger. Check the charging function: output must be 28 volts when charging.
<b>3.0</b>				<b>Actuator</b>
3.1	X	12		Check for suspicious sounds and full movement in all directions, lifting, extension, side shift, tilt and rotation. Defective actuators must be replaced.
3.2	X	12		Cables, cable routes, connectors and connections. Check all cables for breakage and fastening. Check all connectors and connections for poor connection and proper attachment.
<b>4.0</b>				<b>Machine and attachment</b>
4.1	X	12		Base machine. Visual inspection. Welds, damage or excessive wear on parts must be repaired or replaced.
4.2	X	12		Boom. Visual inspection. Welds, damage or excessive wear on parts must be repaired or replaced. Adjust the liner for the extension arm.
4.2	X	12		Attachments Visual inspection. Welds, damage or excessive wear on parts must be repaired or replaced.
4.4	X	12		Bearings and shafts. All moving parts must be checked for wear and clearance. Defective bearings must be replaced. Lubricate all shafts and grease nipples. (B)
4.5	X	6		Tighten all bolts according to the standard thread specification. Be aware that the bolts and screws are secured with Loctite.
<b>5.0</b>				<b>Electronics and safety equipment</b>
5.1	X	1		On/Off key switch. Check the On/Off function.
5.2	X	1		Emergency stop contact. Check the functionality. Repair or replace if necessary.
5.3	X	12		Remote control: • On/Off key switch • Emergency stop switch • Function switches Check all functions. Remedy if this does not work or is damaged, and repair or replace if necessary.



5.4	X	3		Function check of overload.	Use a load to trigger an overload by moving the extension out. When the overload is triggered, all lifting except extension must be deactivated. Retract the load until the overload switch disconnects, and all functions should be functional again. Repair or replace if necessary.
<b>6.0</b>				<b>Propulsion system</b>	
6.1	X	12		Function test of the propulsion system.	Test the throttle in both directions. Test On/Off key switch function on the steering gear Test slow/turtle and fast/hare Function test of belly button.
6.2	X	12	X	Check the brake system.	With the machine moving at full speed, release the throttle. The machine must stop completely within 2 metres. This must be done in both directions and at both speeds (turtle/hare).
6.3	X	12	X	Check the parking brake.	When the machine is stationary, the parking brake must be applied. Test this by pushing and pulling on the machine. It should not be possible to move the machine manually.
	X	12		Check the mechanical brake.	Check the function of the mechanical brake. Test on 8 degree slope.
<b>7.0</b>				<b>Machine and attachment hydraulics</b>	
7.1	X	12		Check the oil level. Oil: Rando 32	The correct oil level is 4 cm below the filling opening, with all cylinders fully retracted.
7.2	X	12		Replace pressure filter	Replace pressure filter.
7.3	X	12		Check all hoses and connection for cracks and leaks.	Check all hoses and replace if necessary.
7.4	X			Check the pressure.	The system should deliver 185 bar (2700 PSI) and then bypass to the tank.
7.5	X	12	X	Function test of all hydraulic functions.	Test all hydraulic functions in full motion and look for leaks and unusual movements.
<b>8.0</b>				<b>External and additional equipment for the machine</b>	
8.1		12		Battery charger for remote control.	Visual inspection. Make sure the device is present and intact.
8.2		12		Extra battery for remote control.	Visual inspection. Make sure the device is present and intact.
8.3		12		Communication cable for remote control.	Visual inspection. Make sure the device is present and intact.
8.4		12		Shoulder strap for remote control.	Visual inspection. Make sure the device is present and intact.
<b>9.0</b>				<b>Static test load</b>	
9.1	X	12		Test with load Follow the load diagram according to the label/manual.	

**Lubrication schedule:**

A = Silicone grease, Kema SC4 or equivalent

B = Calcium sulfonate grease

Bearings are made with Teflon surfaces or oil-rubbed bronze. Lubrication is intended for smaller moving parts.

Issued by:	Date:	Approved by:	Document name.:	Page
TST	24/03/2026	MR	USER MANUAL - SLX 2000 EN 01	39 of 51

## 6.2 Functional inspection

Procedure for inspecting security functions.

### ! ATTENTION!

- **Security features must be inspected according to section 6.1 Overview of service, maintenance and lubrication intervals!**
- **Security features must always be available and functional!**
- **If an inspection of the security features cannot be completed and approved, the machine cannot be used until repairs have been completed and a new inspection has been carried out!**
- **Always inspect security features in an open space where there are no obstacles!**
  
- **On/Off key switch**
  - Turn the On/Off key switch to Off.
  - Checks: All moving functions should now be inoperational.
  - Turn the On/Off key switch to On.
  - Checks: All moving functions should be operational again.
- **Emergency stop**
  - Activate the emergency stop by pushing the emergency stop button manually.
  - Checks: All moving functions should now be inoperational.
  - Deactivate the emergency stop by rotating the button.
  - Checks: All moving functions should be operational again.
- **Off – Remote control**
  - Activate Off by manually pushing the emergency button.
  - Checks: All remote-controlled functions should now be inoperational.
  - Deactivate the emergency stop by rotating the button.
  - Activate On by manually pushing the On button.
  - Checks: All remote-controlled functions should be operational again.
- **Safety switch – Belly button**
  - Activate low driving speed
  - Activate the speed and direction regulator to put the machine in reverse.
  - Activate the belly button by pushing it manually.
  - Checks: The travel direction must be briefly changed, following which propulsion is interrupted.
  - Deactivate the speed and direction regulator and then repeat the procedure at a high driving speed.
- **Parking brake**
  - Turn the On/Off key switch to Off.
  - Checks: It must not be possible to push or roll the machine.
  - Turn the On/Off key switch to On.
  - Checks: It must not be possible to push or roll the machine.
- **Load limit system – Method 1**
  - Lift the rear of the machine so that the rear wheels hover freely above the ground and the load limit switch is interrupted.
    - Tower light: Acoustic alarm and yellow light flashing indicates that the machine is loaded with 90-99% of the lifting capacity.
    - Tower light: Acoustic alarm and red light flashing indicates that the machine is loaded with 100% of the lifting capacity.
  - Checks: The following features must now be inoperational:
    - Side shift
    - Raise / lower
    - Extending

Issued by:	Date:	Approved by:	Document name.:	Page
TST	24/03/2026	MR	USER MANUAL - SLX 2000 EN 01	40 of 51



- Tilt
  - Lower the machine again and dismantle the lifting equipment.
  - Checks: All functions must be operational again.
- **Load limit system – Method 2**
  - Read the load chart on the machine and attachment to see what the lifting capacity is at fully extended position. See section **8.4 Load chart**.
  - Then lift a load which exceeds this and extend this forward until the load limit system interrupts the functions.
    - Tower light: Acoustic alarm and yellow light flashing indicates that the machine is loaded with 90-99% of the lifting capacity.
    - Tower light: Acoustic alarm and red light flashing indicates that the machine is loaded with 100% of the lifting capacity.
  - Checks: The following features must now be inoperational:
    - Side shift
    - Raise / lower
    - Extension
    - Tilt
  - Retract the load and unload the machine.
  - Checks: All functions must be operational again.



### 6.3 Cleaning the machine and attachments

- Clean the machine with running water, soap and a soft brush.
  - ! **ATTENTION! Do not use a pressure washer to clean the machine.**
  - ! **ATTENTION! Never direct the jet of water at the engine!**
- Clean the control handle using a cloth with soap and water.
  - ! **ATTENTION! Never direct the jet of water at the control handle!**
- Clean suction cups with ethanol.
- Alternatively, clean suction cups with warm water, soap, and a soft brush.
  - Always rinse afterwards with clean water.
  - Let the suction cups dry at room temperature
- ! **ATTENTION!**
  - **Never direct a water jet at the suction cups!**
  - **Always ensure that no water enters the vacuum system!**
- ! **ATTENTION! Never use the following products to clean suction cups**
  - **Pure glycerine**
  - **Solvents: trichloroethylene, carbon tetrachloride, or hydrocarbons!**
  - **Vinegar-based cleaning agents!**
  - **Sharp objects, metal brushes, sandpaper, etc!**

Issued by:	Date:	Approved by:	Document name.:	Page
TST	24/03/2026	MR	USER MANUAL - SLX 2000 EN 01	41 of 51

## 6.4 Troubleshooting

**!** **ATTENTION!** In case of unexpected failure or malfunctioning of the machine, the machine must be stopped immediately, and the fault must be reported to Smartlift customer service immediately via tel. +45 97 72 29 11 or via email [customerservice@smartlift.com](mailto:customerservice@smartlift.com).

No.	 Problem	 Cause	 Solution
1.	No response to: <ul style="list-style-type: none"> <li>• Drive functions</li> <li>• Move functions</li> </ul>	<ul style="list-style-type: none"> <li>• The power has been interrupted</li> <li>• The batteries have been discharged</li> <li>• The emergency stop has been pushed</li> <li>• Fuse has blown</li> </ul>	<ul style="list-style-type: none"> <li>• Turn the main switch</li> <li>• Check the battery level</li> <li>• Release the emergency stop</li> <li>• Check fuses</li> </ul>
2.	No response to: Drive functions	<ul style="list-style-type: none"> <li>• The engine has no electricity</li> <li>• The brake does not release</li> <li>• On/Off key switch which is set to "Off"</li> </ul>	<ul style="list-style-type: none"> <li>• Check point 1.</li> <li>• Press the "On" button</li> <li>• Check fuse for motor control</li> </ul>
3	No response to: Move functions	<ul style="list-style-type: none"> <li>• The load limit system has interrupted the functions due to overload</li> <li>• The pump does not start</li> <li>• The remote control is not connected (RED LED on the left side of the emergency stop is illuminating).</li> <li>• The machine is out of range (100m / 109yd)</li> </ul>	<ul style="list-style-type: none"> <li>• Retract the extension boom</li> <li>• Check point 1.</li> <li>• Reset the remote control by holding down the "On" button for 5 seconds.</li> </ul>

## 6.5 Fuses

Fuse by the charger		
Size	Function	Position
250A	Motor and hydraulic	By the charger
60A	Controller and servo motor	By the charger
50A	Charger	By the charger
40A	Control box	By the charger
Fuses in the control box		
Size	Function	Position
10A	Vacuum pump	Slot F01
10A	Vacuum pump	Slot F02
2A	Controle handle	Slot F03
2A	Emergency stop	Slot F04
5A	Main switch	Slot F05
3A	Charger for remote control	Slot F06
10A	Remote control receiver	Slot F07
2A	Tracker	Slot F08
	Extra	Slot F09
15A	Supply for control	Slot F10
	Extra	Slot F11
	Extra	Slot F12
	Extra	Slot F13
2A	Start interrupt (while charging)	Slot F14
10A	Tracker and charger for remote control battery	Single fuse holder

## 6.6 Spare parts



If spare parts are needed, these can be ordered by contacting your nearest dealer or Smartlift Customer Service at tel. +45 97 72 29 11 or email: [customerservice@smartlift.com](mailto:customerservice@smartlift.com)

## 7 Scrapping and disposal

The machine and/or attachments must be scrapped and disposed of in accordance with local regulations.

## 8 Annexes

### 8.1 Terms and abbreviations

Term	Text
 Warning!	Things that can cause bodily injury or death
 Attention!	Things that can cause bodily injury or property damage
The user	The person who operates the machine and is responsible for security
The machine	SLX 2000
The load	The object to be lifted
Wind load	Effect of wind on the load and machine

Abbreviation	Significance
SLX	Smartlift multi-purpose machine
WLL	Working Load Limit / Maximum lifting capacity

## 8.2 Declaration of conformity – Machine

Manufacturer and bearer of responsibility for the compilation of technical files:

Morten Rosengreen  
 Head of Development  
 Smartlift A/S  
 N.A. Christensensvej 39  
 DK - 7900 Nykøbing Mors



Hereby declares that:

Model:

SLX 2000

Serie no.: \_\_\_\_\_

Date: \_\_\_\_\_ - \_\_\_\_\_ - 20\_\_\_\_

has been manufactured in accordance with the following EC directives:

The Machinery Directive 2006/42EC

The EMC Directive 2014/30/EU

The following standards have been used:

EN ISO 12100:2011 (Machine safety – General principles for design – Risk assessment and risk reduction)

EN ISO 20607:2019 (Machine safety – Instruction handbook – General drafting principles)

EN ISO 14121-2:2012 (Machine safety – Risk assessment - Part 2: Practical guidance and examples of methods)

EN ISO 4413 (Hydraulic fluid power – General rules and safety requirements for systems and their components).

Date: \_\_\_\_\_

Signature: \_\_\_\_\_



N. A. Christensensvej 39, DK-7900 Nykøbing Mors  
 Tel. +45 9772 4900, E-mail: smart@smartlift.com

**Nicolai Tange Jørgensen, CEO**

Issued by:	Date:	Approved by:	Document name.:	Page
TST	24/03/2026	MR	USER MANUAL - SLX 2000 EN 01	45 of 51

### 8.3 Declaration of conformity – Attachments

Manufacturer and bearer of responsibility for the compilation of technical files:

Morten Rosengreen  
 Head of Development  
 Smartlift A/S  
 N.A. Christensensvej 39  
 DK - 7900 Nykøbing Mors



Hereby declares that:

Model:

- |                          |                 |                  |                              |
|--------------------------|-----------------|------------------|------------------------------|
| <input type="checkbox"/> | Vacuum yoke     | Serie no.: _____ | Date: _____ - _____ - 20____ |
| <input type="checkbox"/> | Hydraulic winch | Serie no.: _____ | Date: _____ - _____ - 20____ |
| <input type="checkbox"/> | Fly-Jib         | Serie no.: _____ | Date: _____ - _____ - 20____ |
| <input type="checkbox"/> | Lifting hook    | Serie no.: _____ | Date: _____ - _____ - 20____ |
| <input type="checkbox"/> | Pallet fork     | Serie no.: _____ | Date: _____ - _____ - 20____ |

has been manufactured in accordance with the following EC directives:

The Machinery Directive 2006/42EC  
 The EMC Directive 2014/30/EU

The following standards have been used:

EN ISO 12100:2011 (Machine safety – General principles for design – Risk assessment and risk reduction)

EN ISO 20607:2019 (Machine safety – Instruction handbook – General drafting principles)

EN ISO 14121-2:2012 (Machine safety – Risk assessment - Part 2: Practical guidance and examples of methods)

EN ISO 4413 (Hydraulic fluid power – General rules and safety requirements for systems and their components.

Date: \_\_\_\_\_

Signature:   
**Nicolai Tange Jørgensen, CEO**



N. A. Christensensvej 39, DK-7900 Nykøbing Mors  
 Tel. +45 9772 2990, E-mail: smart@smartlift.com

Issued by:	Date:	Approved by:	Document name.:	Page
TST	24/03/2026	MR	USER MANUAL - SLX 2000 EN 01	46 of 51

## 8.4 Load charts

Each load chart only applies to machine with the specified attachment.

### 8.4.1 SLX 2000 – Vacuum yoke

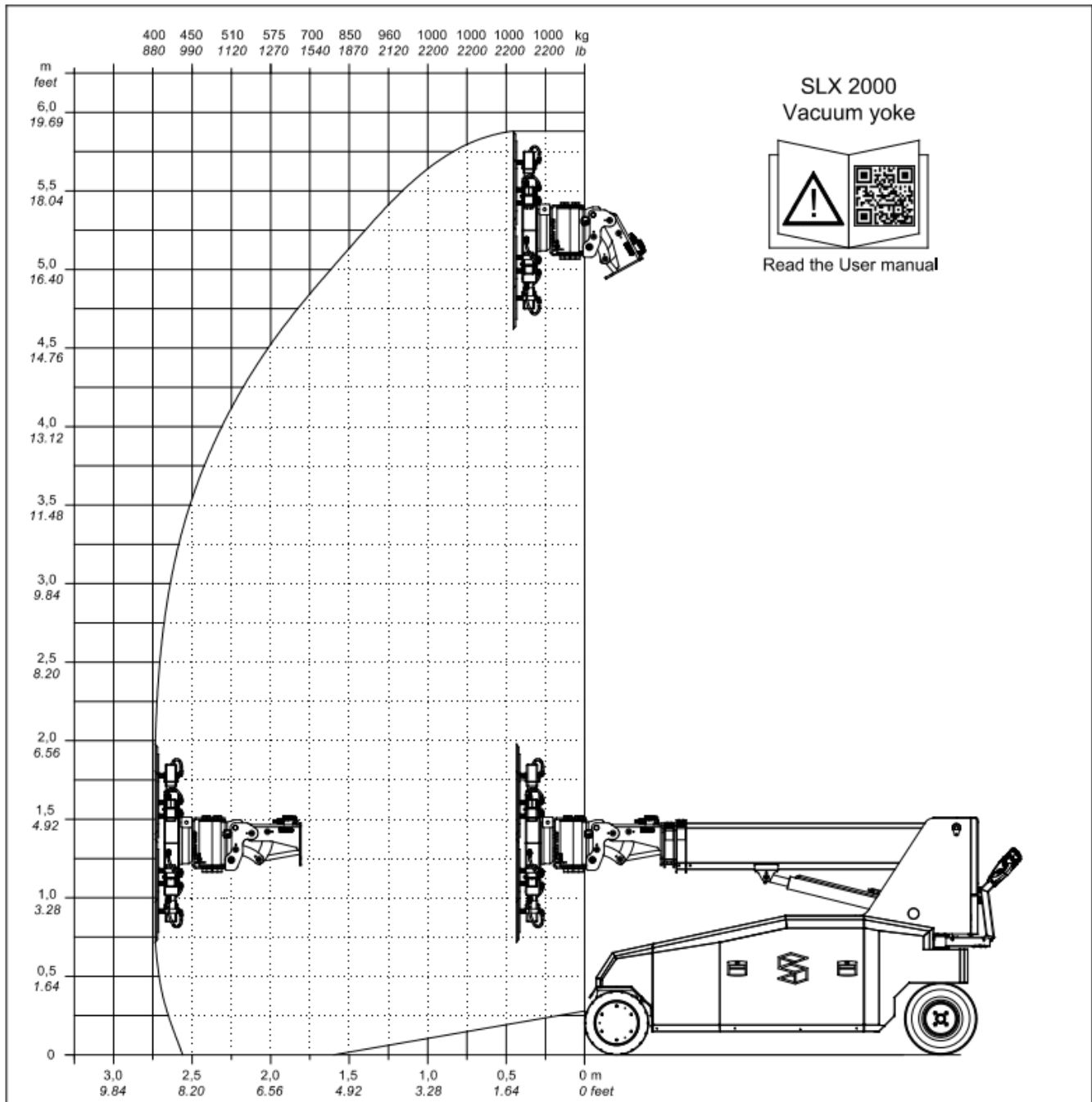

Issued by:	Date:	Approved by:	Document name.:	Page
TST	24/03/2026	MR	USER MANUAL - SLX 2000 EN 01	47 of 51

### 8.4.2 SLX 2000 – Hydraulic winch

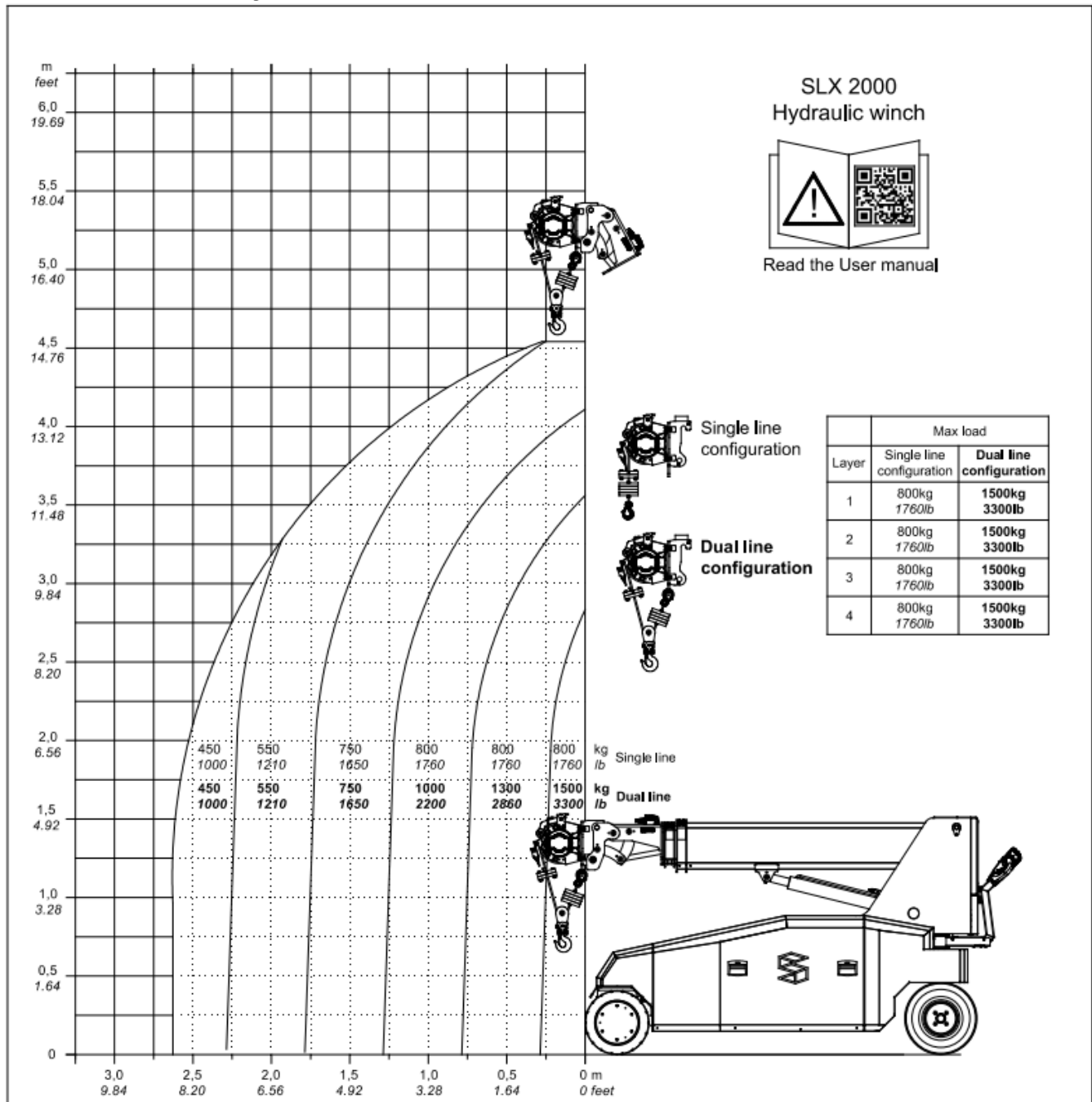

### 8.4.3 SLX 2000 – Fly-Jib

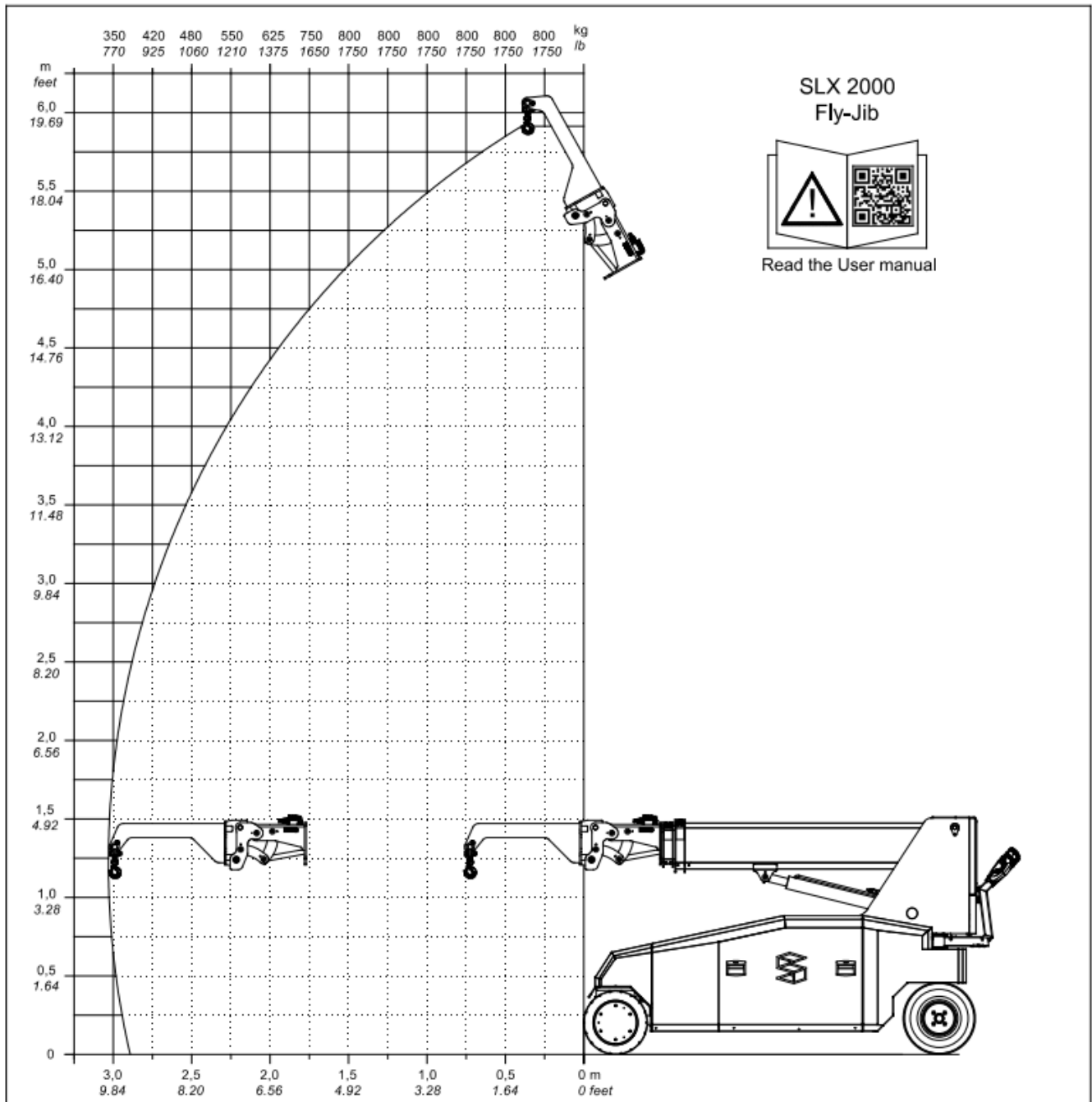

### 8.4.4 SLX 2000 – Lifting hook

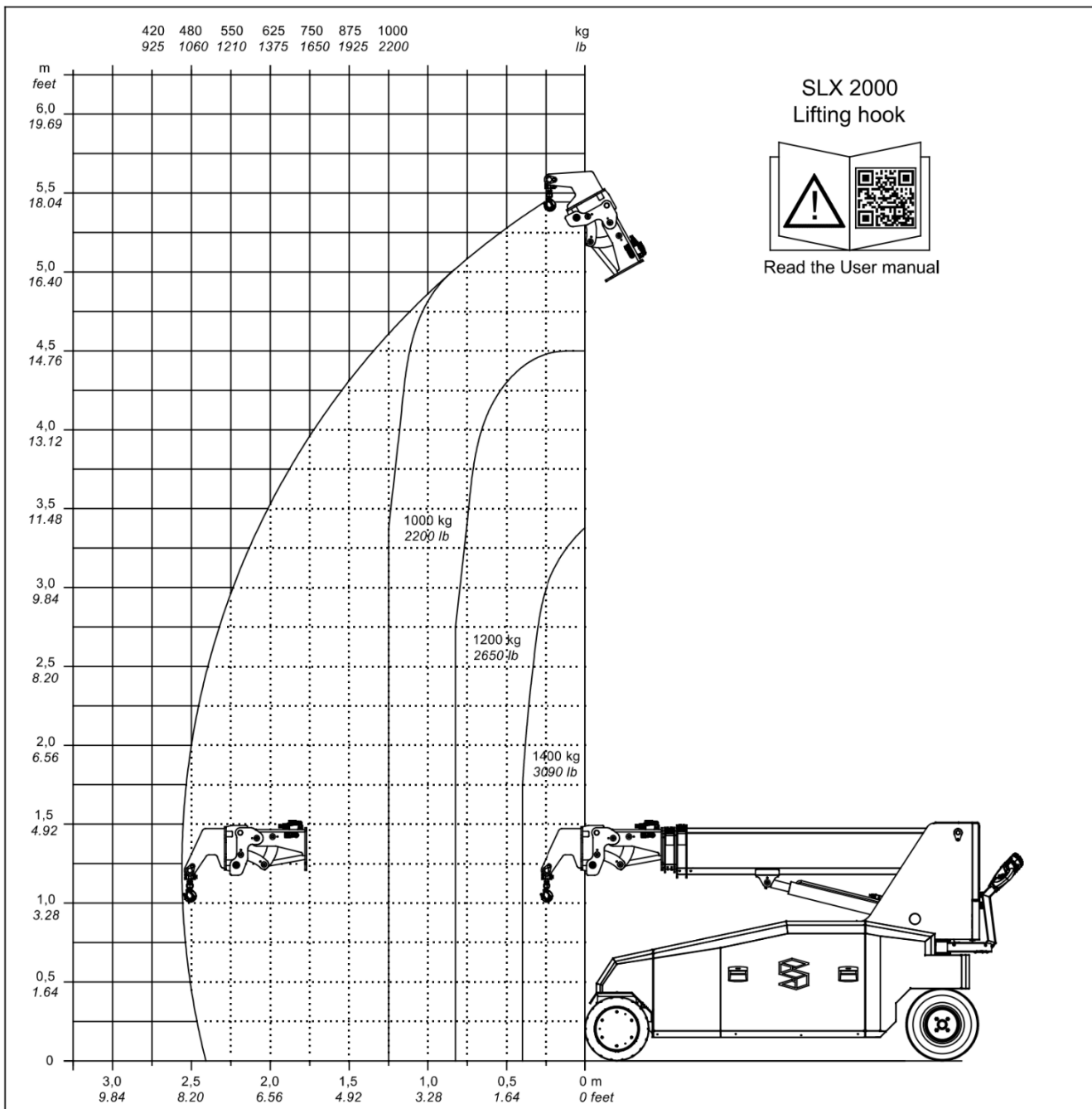

### 8.4.5 SLX 2000 – Pallet fork

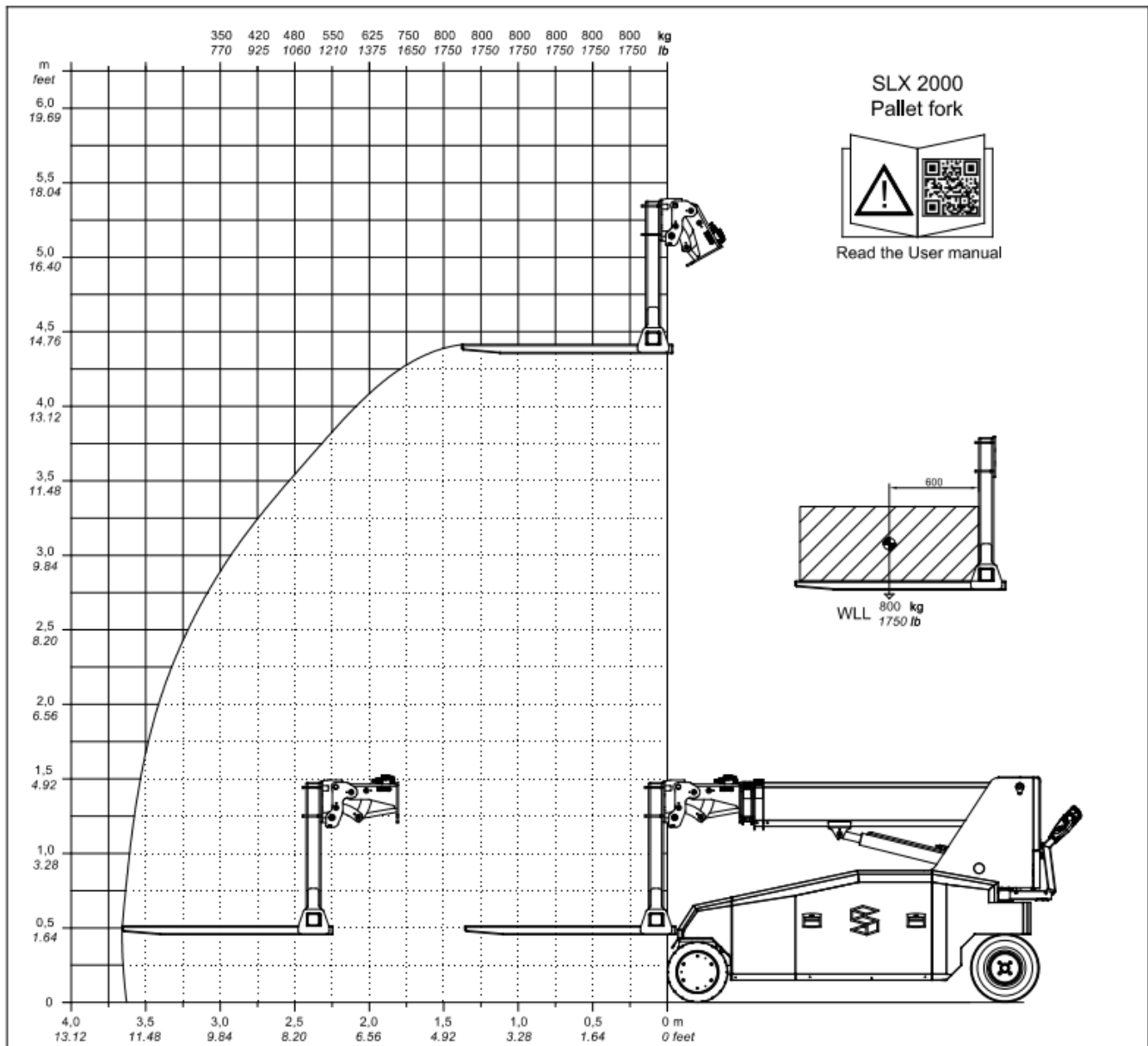

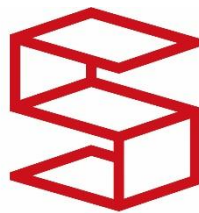

**SMARTLIFT<sup>®</sup>**

N.A. Christensensvej 39,  
DK-7900 Nykøbing Mors  
Tel.: +45 97 72 29 11

E-mail: [smart@smartlift.com](mailto:smart@smartlift.com)  
[www.smartlift.com](http://www.smartlift.com)